



# OWNER/INSTALLATION MANUAL

AIR-SOURCE CO2 HEAT PUMP HOT WATER SYSTEM

INSTALLATION  
OPERATION  
MAINTENANCE  
WARRANTY



**RECLAIM**  
ENERGY

## COVERING MODEL NUMBERS (FOR STC CLAIMS):

REHP-C02-160GL

REHP-C02-250GL

REHP-C02-315GL

REHP-C02-400GL

REHP-C02-160SST

REHP-C02-250SST

REHP-C02-315SST

REHP-C02-315SSQ

REHP-C02-400SST

REHP-C02-250SS-WIL

REHP-C02-315SS-WIL

REHP-C02-250SSEW

REHP-C02-315SSEW

## IMPORTANT

This appliance is not intended for use by persons (including children) with reduced physical, sensory or mental capabilities, or lack of experience and knowledge, unless they have been given supervision or instruction concerning use of the appliance by a person responsible for their safety. Children should be supervised to ensure that they do not play with the appliance.

## WARNING

This appliance may deliver water at high temperature. Refer to the Plumbing Code of Australia (PCA), local requirements and installation instructions to determine if additional delivery temperature control is required.

---

Issue 07 | Aug 2021

<b>SECTION</b>	<b>PAGE</b>
1 Terminology	4
2 First Time Commissioning Procedure	5
3 Product specification overview (heat pump and tank are split)	6
4 System description: How it works	10
5 Technical specifications	11
6 Installation details	15
7 Operational and maintenance details	31
8 Warranty	39

## TERMINOLOGY

The following table provides descriptive definitions of common terminology used throughout this manual and other documents and materials relating to your Air-Source CO2 Hot Water System.

<b>ASHP</b>	Air-Source Heat Pump, which is a device including different parts such as evaporator and compressor that heat up water using ambient air as the primary energy source.
<b>ACL</b>	Australian Consumer Law is the national law for fair trading and consumer protection.
<b>Brass Fittings</b>	Fittings used to connect manifold to manifold (connectors), or fittings related to connecting the manifold to copper pipe (elbows or straight fittings). These are made out of brass material.
<b>Claim</b>	Any claim, action, proceeding, loss, damage, cost, expense or liability whatsoever incurred or suffered by or brought or made or recovered against any person and however arising (whether or not presently ascertained, immediate, future or contingent)
<b>Controller</b>	Device used in the Heat Pump system to set the temperature requirements of the system to control relays such as pumps.
<b>Corrosion</b>	Process that involves deteriorating material due to oxidation. Customer Person(s) or body/bodies corporate to whom these terms and conditions are directed.
<b>Cylinder</b>	Refers to the tank cylinder.
<b>ECV</b>	Expansion control valve: Installed on the cold mains line to relieve excess pressure. The customer needs to consult with a certified plumber/installer.
<b>ACL</b>	Air-Source Heat Pump, which is a device including different parts such as evaporator and compressor that heat up water using ambient air as the primary energy source.
<b>Electrical Conductivity</b>	Amount of dissolved material in water, which relates to its ability to conduct electrical current through it.
<b>Hardness</b>	Water that is high in dissolved minerals.
<b>Insulation</b>	Materials used for heat retention.
<b>pH Level</b>	Measure of how acidic/basic water is.
<b>PTR Valve</b>	Pressure Temperature Relief Valve (PTRV): Installed on the hot water storage tank to relieve pressure, and excessive temperatures. The temperature default setting is 99°C for temperature and 850 kPa for pressure.
<b>PLV Valve</b>	Pressure limiting valve is installed on the cold main inlet of water to the system. The setting shall be 500 kPa.
<b>Tempering Valve</b>	A valve that mixes hot and cold water before supply to the hot water taps. The default setting is 50°C.
<b>Storage Tank</b>	Container holding volume of water.

# FIRST TIME COMMISSIONING PROCEDURE

## STEP 1

- Ensure you have filled the tank and purged all the air by opening a tap inside the house. The tank will be purged when water runs freely from the tap.
- Turn tap off.
- The cylinder has now been purged.

## STEP 2

- Purge the circulating pump by loosening the brass 8mm nut on the underside of the heat pump until water runs freely then tighten again.
- The circulating pump has now been purged.

## STEP 3

- Initiate auto purge and system start up.
- Ensure the system controller is turned on and the time is displayed.
- Ensure the heat pump isolator is in the on position and power is on to heat pump unit.
- The heat pump LED display will be blank, don't worry if nothing is displayed here, this display only displays error codes. All displays are accessed from the system controller.

- On the left hand side of the controller are 3 buttons.
- Push and hold the bottom button "menu" until the word "purge" is displayed and flashing (approx 5 seconds).
- Now let go of the button.
- In about 4 seconds you should hear the on-board circulating pump come on.

### NOTE 1

**Remember to drain and purge the heat pump on commissioning (otherwise system might fail) – the "drain plug" is shown below. Also, remember to drain from hot water taps inside the house.**

### NOTE 3

**Maximum horizontal distance is 10 m and vertical distance is 5 m between heat pump and tank (max of 3 bendings)**

### NOTE 2

**Sensor probe must be fully inserted and secured (using gland or silicon plug) in the bottom tank sensor. The sensor cable comes with a rubber sleeve. Fully push the sensor in and then push the cable sleeve until only 6 mm is protruding. Then tighten up the gland so the sensor is firmly held.**

## SYSTEM START-UP SEQUENCE

The system is now starting up and will go through the following sequence:

- 1 The system will run a 5 minute purge that pushes any air within the heat pump unit into the tank. Note the unit fan won't be turning at this point).
- 2 After this 5 minute period the pump will stop and the fan will turn slowly. The system will not be heating up until the until can maintain a consistent 63°C (this may take up to 4 minutes).
- 3 The unit fan comes on properly and the circulating pump starts to circulate that constant 63°C water through the tank.

Due to the smart top down heat return system your customer will have 50L of hot water within 20 minutes and a full tank in about 3 hours.

After 15 minutes touch the heat pump return connection to the tank and ensure it is hot to touch, if you feel good heat here you are done and can comfortably leave knowing you have completed the install successfully.

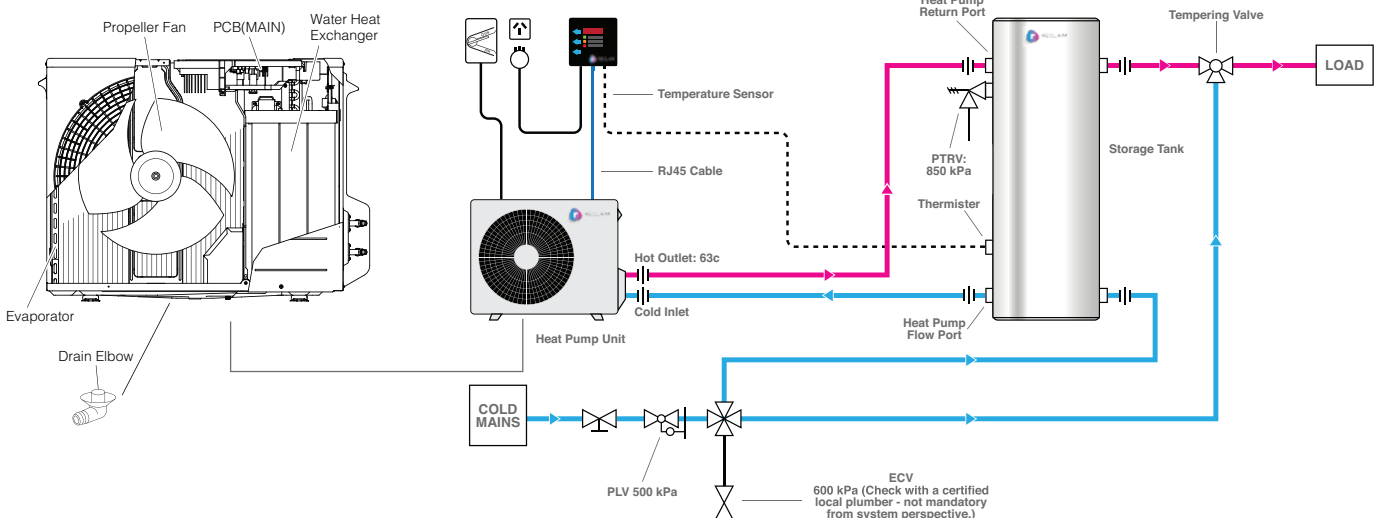

## PRODUCT SPECIFICATION OVERVIEW

The summary of Reclaim Energy heat pump hot water system specification is tabulated below. Note: Heat pump and tank tables are separate.

### HEAT PUMP

PARAMETER	UNIT	VALUE
Model Number	-	EHPE-4540P
Max. heat output	kW	6.0
Max. Rated current input	A	10.0
Max. Rated Power input	kW	2.3
Breaker size	A	20
Heat pump refrigerant	-	CO2 (R744)
Heat pump hot water delivery temperature	°C	63
Range of operating ambient temperature	°C	-10 to 43
Heat pump unit weight	Kg	48
Heat pump location	-	Outdoor
Noise level	dB	37

\* This tank model ID shares heat pump return and PTRV port via a tee valve connection

## CONTROLLER

PARAMETER	UNIT	VALUE
<b>Model ID</b>	–	RCE-HP-CONT-V1
<b>Controller power supply voltage and frequency</b>	V/Hz	240/50 (single phase)
<b>Signal from the controller to heat pump</b>	V/Hz	12/50
<b>Controller location</b>	–	Mounted on wall or tank
<b>Heat pump on/off temperature (based on tank Thermistor)</b>	°C	37/59
<b>Operational hours (default timer settings)</b>	hr	24 (continuous)

## CERTIFICATION

The product has been certified/tested successfully under the following Australian standards:

AS 5125.1, AS 4020, AS 3498, AS 2712, AS 60335.1, AS 60335.2.40, AS Watermark Certification

## PRODUCT SPECIFICATION OVERVIEW CONT.

Reclaim Energy offers a range of storage vessels including glass lined and stainless steel options. Tank port/sensor locations as well as the tank specifications are provided in Figure 1 and Table 3. Note that the tanks supplied have been designed to minimise the heat loss from the tank during its operation.

**NOTE**

The AP315AGLH model number ONLY, uses the same port for the return line as the PTRV port on top of the tank. This is done via a tee valve connection – please refer to installation details in Section 5. For all other model numbers, there are separate connection ports on the tank for the PTRV port and heat pump return line.

		GLASS LINED			
SYSTEM MODEL ID	UNIT	REHP-CO2-160GL	REHP-CO2-250GL	REHP-CO2-315GL	REHP-CO2-400GL
TANK ID		RE160AGLH	RE250AGLH	AP315AGLH* & RE315AGLH	RE400AGLH
<b>PTRV Rating</b>	kPa	850	850	850	850
<b>Glass Lined (GL) or Stainless Steel (SS)</b>		GL	GL	GL	GL
<b>Total physical volume</b>	L	163	259	323	420
<b>Diameter (A)</b>	mm	528	613	617	701
<b>Height (B)</b>	mm	1317	1439	1765	1699
<b>Hot water outlet (D)</b>	mm	1099	1212	1531	1447
<b>PTRV port (H)/heat pump return (C)</b>	mm	1099	1212	1531	1447
<b>Sensor (G)</b>	mm	439	458	560	556
<b>Cold Water inlet/HP Flow (E/F)</b>	mm	189	196	197	221

\* This tank model ID shares heat pump return and PTRV port via a tee valve connection

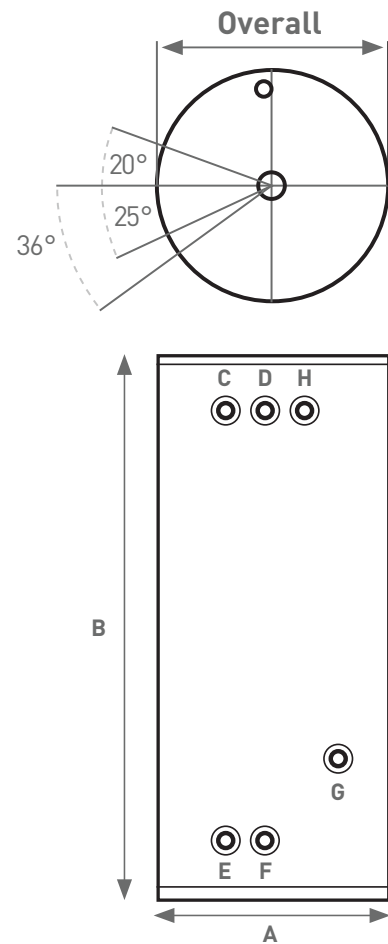

PARAMETER	UNIT	VALUE
<b>Tank unit weight (empty)</b>	Kg	160 > 58 250 > 72 315 > 92 400L > 106
<b>PTRV pressure</b>	kPa	850
<b>Thermistor level on tank (depending on tank model ID)</b>	%	55 to 69
<b>Tank location</b>	-	Indoor/Outdoor
<b>Maximum distance between tank and the heat pump unit</b>	m	10m Horizontal 5m Vertical

**STAINLESS STEEL**

REHP-C02-160SST	REHP-C02-250SST	REHP-C02-315SST	REHP-C02-315SSQ	REHP-C02-400SST	REHP-C02-250SS-WIL	REHP-C02-315SS-WIL	REHP-C02-250SSEW	REHP-C02-315SSEW
APS160TH	APS250TH	APS315TH	APS315SH	APS400TH	RE250WIL	RE315WIL	EWA-250HPT	EWA-315HPT
700	700	700	700	700	850	850	700	700
SS-Tall	SS-Tall	SS-Tall	SS-Squat	SS-Tall	SS	SS	SS	SS
180	280	330	333	420	268	327	250	315
565	565	565	685	680	620	620	620	620
1200	1800	2090	1490	1850	1680	2007	1620	1990
940	1588	1850	1205	1588	1455	1783	1184	1538
940	1588	1850	1205	1588	1455	1783	1437	1739
343	608	730	470	608	548	633	574	762
196	196	210	210	196	233	233	163	163

## SYSTEM DESCRIPTION

The following system description section provides a brief overview of the the Air-Source CO2 Hot Water Pump's main components and functionality.

### 4.1 MAIN COMPONENTS

The system components of the air sourced heat pump that customers will receive include:

Heat pump Unit, Storage Tank with PTRV, Controller, Heat pump mounting legs.

### 4.2 SYSTEM OPERATION

The CO2 heat pump unit receives cold water from the bottom of the tank. Using the heat from the ambient air the heat pump heats the CO2 refrigerant to generate hot water. The hot water returning from the heat pump unit (fixed at 63°C) is injected into the top of the tank to provide fast hot water recovery and excellent hot water stratification. As this system delivers hot water exceeding 50 °C, a tempering valve must be installed for delivery of hot water to bathrooms. Untempered water may be delivered to kitchen and laundry according to AU/NZS AS 3500 plumbing code.

The heat pump operation is controlled by an external controller. The controller operates based on a sensor connected to the tank at 55 – 69% level depending on tank model i.d. The heat pump will be turned on if the temperature at the sensor level on the tank drops below 59°C for the first cycle or 37°C for the second cycle in a day and it will be run until the tank temperature at sensor level reaches 59°C. The system controls are designed to ensure that it meets the legionella requirements as specified in the Australian standards. The heat pump will run until the sensor level on the tank reaches 59°C. In the subsequent heating cycles of every 24-hour period, the heat pump "turn off" logic is adjustable by built-in timer settings.

The default timer setting is programmed to run on continuous operation but this can be adjusted by the installer based on the home owner requirements to suit their needs. More details regarding the controller operation and settings is outlined in Section 6.

At ambient temperatures below 5.5°C, frosting may occur, if this happens the heat pump will go into defrost mode in order to protect the unit (i.e. this defrost functionality will turn the heat pump on and will normally run for no more than 15 minutes in duration). When the unit is in the defrost function the pump and fan will stop and the refrigerant heat will defrost the evaporator. As defrost advances, the evaporator temperature will increase.

When a set temperature [preprogrammed] is achieved, the defrost operation stops and the heat pump will operate in line with its normal settings. More details regarding the controller operation and settings is outlined in Section 6.

The "operational window" in this context refers to heat pump "hot water production" mode which can be set by using one of the options on the controller. From time to time, especially during the winter and in very cold climates, the heat pump operation may be disrupted or extended by a built-in anti-freeze or defrost operational mode. The defrost cycle can occur ONLY during the operational window to defrost the ice build-up on the evaporator at the back of the unit which is an air-CO2 heat exchanger. The defrost cycle occurs when the ambient temperature is less than about 5 °C. During the defrost operation, the fan and pump stop, and the high-temperature refrigerant which is originally used for hot water production shall be supplied in order to melt frosts on the evaporator (=air-CO2 heat exchanger).

The frost cycle can take about 5 minutes and this can happen multiple times depending on the ambient temperature, so in total, up to 20 minutes can be expected for the entire defrost cycle. The heat pump also comes with a built-in freeze protection cycle. Anti-freeze operation can ONLY occur outside the operational window of the heat pump and the purpose of the cycle is to protect the water circuit (i.e. piping between tank and heat pump) from water freezing. If the ambient and water pipe temperatures drop below 3 °C, the heat pump will do the anti-freeze operation. During the anti-freeze operation, the heat pump works as a normal heating cycle so the fan and pump should be running. The anti-freeze operation stops when the water inlet temperature reaches 56 °C or ambient temperature reaches 6 °C.



Figure 2: Photo of a Reclaim Energy heat pump hot water system.

# TECHNICAL SPECIFICATIONS

This section summarises the main technical specification of the Reclaim Energy heat pump hot water system.

## 5.1 HEAT PUMP

The dimension and section views of the heat pump are displayed in Figure 3. The five main internal components of the heat pump are:

The fan, the evaporator, the compressor, the pump, and the water/refrigerant heat exchanger. The detailed specification of these major components are provided in Table 4.

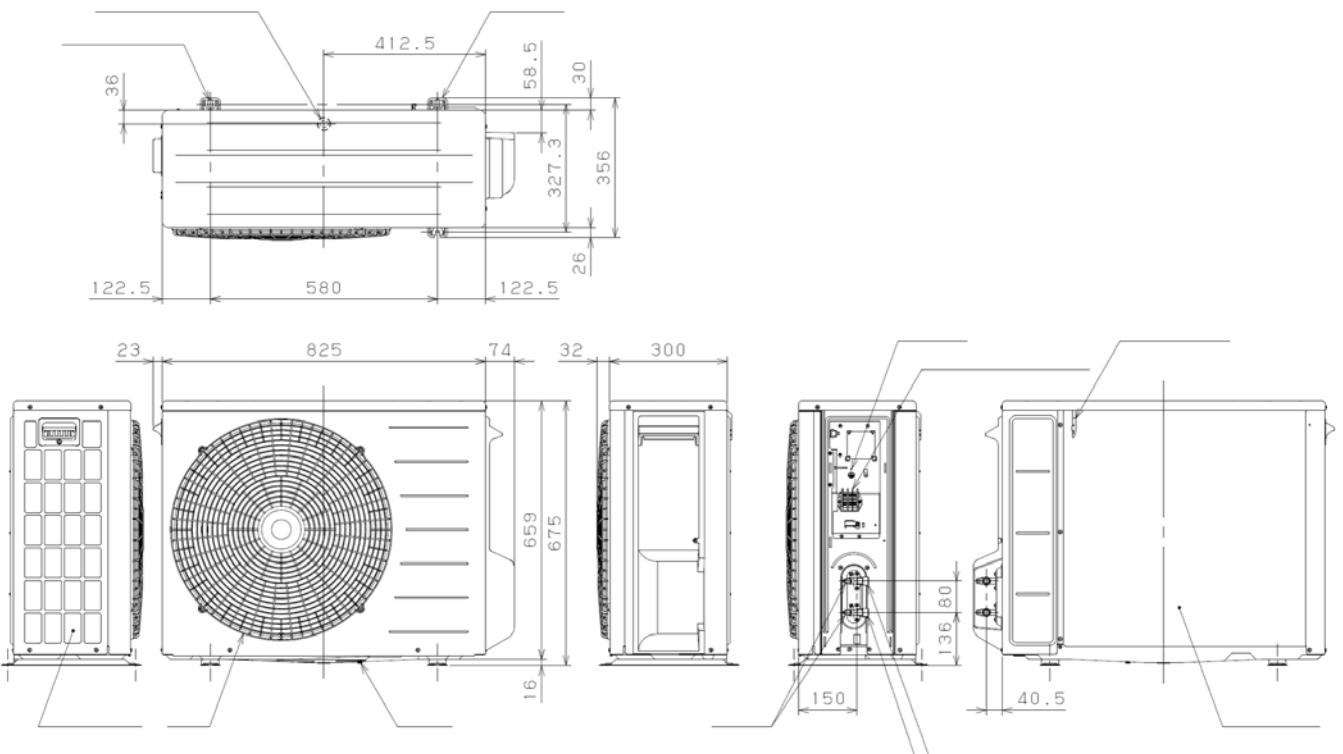

Figure 3: Heat pump unit detail top/front/side view (all dimensions are in mm).

## TECHNICAL SPECIFICATIONS CONT.

## HEAT PUMP UNIT

## MODEL ID- EHPE-4540P

PARAMETER	UNIT	VALUE
Power input *	kW	0.87
Thermal output *	kW	5.24
COP *	-	6.02
Refrigerant	-	CO2 (R744)
Output water temperature	°C	63
Power supply	V/Hz	240V/50 Hz
Current input (Max)	Amps	10
Power input (Max)	kW	2.3
Noise level	dB	37
Ambient temperature	°C	-10 to 43
Dimension (H x W x D)	mm	675 x 825 x 300
Weight	kg	48
Rain resistance	-	IP*4
Water port connections (inlet/outlet)	Inch/mm	1/2" BSP, 12.7mm

Table 4: Detailed specifications of heat pump unit major components.

**TEST CONDITIONS**

Outlet water setting 63°C

Inlet cold water 21.1°C

Ambient temperature dry bulb 32.6°C

## 5.2 CONTROLLER

The controller is the electronic interface between the storage tank and heat pump. The control unit has been designed to allow home owners and installers to interface with the operations of the unit to ensure it functions in the most efficient manner possible for householders. The unit incorporates a real time clock, as time-based heat pump operational periods are user selectable. The controller self-checks itself to ensure the storage tank temperature reaches 59 °C at least once a day as part of our legionella control mechanism. The unit is enclosed in a weather proof enclosure which is generally mounted to the side of the storage tank. The default display is time of day, while tank temperature can be briefly displayed if desired. Three status LEDs provide additional information as detailed in the controller user manual. The module is supplied prewired to reduce installation time. Supplied components associated with the controller are shown in Figure 4. The controller components are shown in Figure 5. Also, detail specifications of the controller is given in Table 5.



Figure 4: A photo of supplied controller unit.

1. The controller Module
2. Pre-fitted 230v power lead.
3. Pre-fitted Temperature Sensor.
4. Pre-fitted RJ45 10 meter patch lead.
5. CR2032 Lithium battery.
6. 4 No. securing screws.
7. 4 No. nylon spacers.

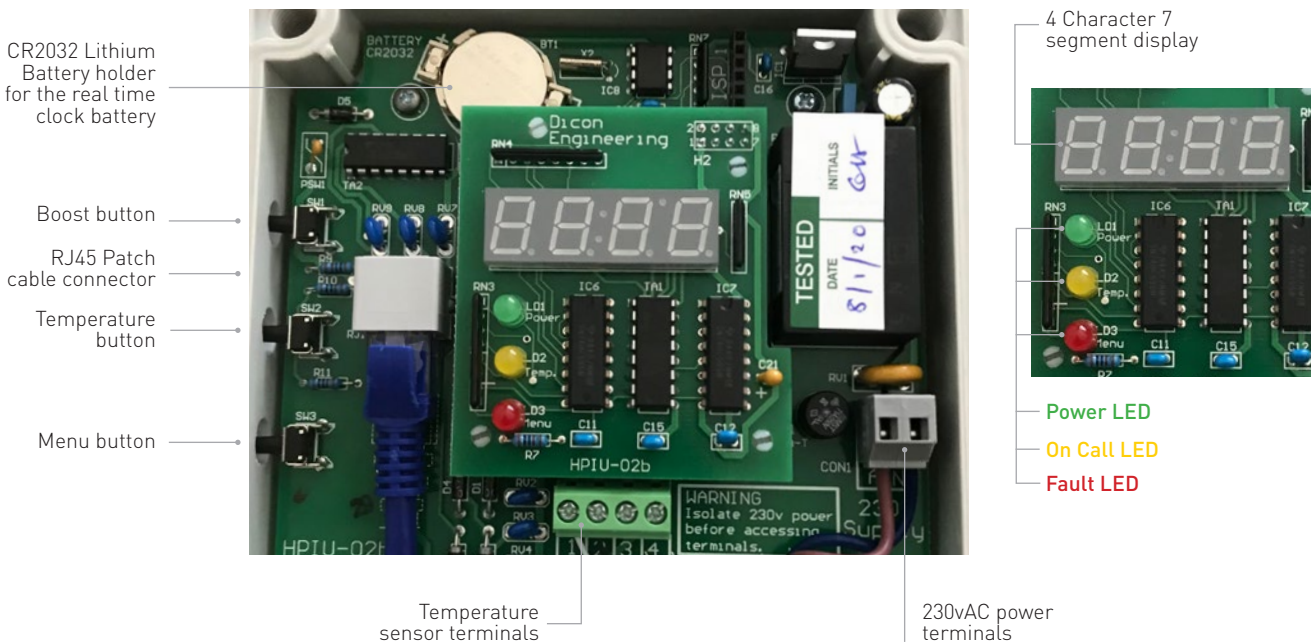

Figure 5: Detailed graphic description of the controller module

## TECHNICAL SPECIFICATIONS CONT.

ITEM	DESCRIPTION	DETAILS
<b>User selectable</b>	Operational modes	<b>Option 1:</b> 24/7 operation <b>Option 2</b> (off-peak 1 per CER method): 10 pm – 7 am <b>Option 3:</b> 12 am – 6 am (6 hours) <b>Option 4:</b> 10 am – 4 pm <b>Option 5:</b> timer with two zones for customised operations
<b>User selectable</b>	One-off heating cycle (overwrite the operational mode and revert back after completion)	One-shot boost button
<b>Enclosure</b>	Dimension (mm)	130H x 130W x 35D
	Material	Polycarbonate
	Mounting	Screw mountable
<b>Connectors</b>	–	RJ45 for Heat Pump Interconnection Fixed screw connect terminals for Power and Temperature Sensors
<b>Power Requirements</b>	–	80 – 264vAC 47-63Hz
<b>Operating Temperature</b>	–	-25 to 75oC
<b>Input Requirements</b>	–	Input (CON2, Term 1-2): Temperature Sensor, 10kohm @ 25oC NTC
<b>Fixed Time Delays</b>	Inputs (Heat Pump)	100mS
	Push Button Inputs	50mS
	Temperature Sensor Fault ON/Off	3 seconds
	Temperature Mode ON/Off set point	3 seconds
	Purge Mode	5 seconds
	Temperature Display Mode	20 seconds
	Menu Display Mode	30 seconds
<b>RTC Battery back-up</b>		CR2032 Lithium battery
<b>Kit Contents</b>		Controller Module 230v Australian approved power cable & plug (pre-fitted) RJ45 10 meter patch cable (pre-fitted) Temperature Sensor & 2 meter lead (pre-fitted) Mounting screws and spacers x 4 CR2032 battery

Table 5: Detail specification of the controller module.

## INSTALLATION DETAILS

This section relates to the preparation and the installation process for the Reclaim Air-Source CO2 Heat Pump system.

The installation of a Reclaim Energy air source heat pump can only be completed by a licensed plumber or electrician in accordance with the local standards and regulations please see:

- AS/NZS 3500.4 – National Plumbing and Drainage Code
- AS/NZS 3000 – Electrical installation
- AS/NZS 2712.2007 – Solar and Heat Pump Water Heaters: Design and Construction
- AS/NZS AS 3498—2009 – Water heaters and hot-water storage tanks

A licensed installer must adhere to occupational health and safety guidelines and other relevant industry associations. Under no circumstances should any installer attempt to install a Reclaim Energy system without reading and understanding this installation manual. For any queries Reclaim Energy staff may be contacted on 1300 38 38 15.

Note that the Reclaim Energy system has been designed to provide hot water for domestic applications only, other applications such as space heating are not supported by this product. Installing the unit for any other application other than for domestic hot water application will void the warranty. The installation guide for each major component of the system as well as the whole system is covered in this section.

The following sequence is recommended for installation:

1. Conduct site inspection
2. Identify heat pump and tank installation location
3. Plan system integration: Piping and fittings
4. Testing and commissioning

### 6.1 SITE INSPECTION AND INSTALLATION PREPARATION

The very first step of installation is to find an appropriate location for the installation of the heat pump unit that includes: heat pump, tank, timer, and the controller. It is recommended that:

- To reduce the heat loss from piping, the whole system should be installed as close as possible to the main hot water points in the house (kitchen and/or bathrooms).
- The maximum distance between controller/timer, tank, and heat pump should not exceed 10 m. .
- It is recommended that the heat pump is installed on the ground next to the tank.
- The heat pump unit **MUST** be installed outdoors, the tank can be installed indoors.
- The back of heat pump unit draws in ambient air therefore it **MUST NOT** be covered. In order to have sufficient air circulation behind the heat pump, the minimum free space should be 0.15 m.
- The system requires at least two GPO power outlets (one for controller, one for heat pump).
- The mounting surface of tank and heat pump **MUST** be horizontal.
- The clearance on front and back of the unit are 350 mm and 600 mm- please refer to Figure 8.
- The tank **MUST** be installed on a concrete slab on the ground.
- Water supply quality must be in line with the specifications of the heat pump unit and the storage tank being installed.

## INSTALLATION DETAILS CONT.

Water quality is an important aspect that can influence the systems operations and functionality. For the system to be warranted the water used in the system must meet the requirements outlined in Table 6 below.

<b>Total Dissolved Solids</b>	< 600 mg/L or ppm
<b>Total Hardness (CaCO<sub>3</sub>)</b>	< 200 mg/L or ppm
<b>Electrical Conductivity</b>	850 µS/cm
<b>Chloride</b>	< 300 mg/L or ppm
<b>pH Level</b>	Min 6.5 to Max. 8.5
<b>Magnesium</b>	< 10 mg/L or ppm
<b>Sodium</b>	< 150 mg/L or ppm
<b>Iron</b>	< 1mg/L or ppm
<b>Alkalinity (as CaCO<sub>3</sub>)</b>	< 200 mg/L or ppm
<b>Dissolved (free) CO<sub>2</sub></b>	< 25 mg/L or ppm

Table 6: Water Quality Threshold Values.

If you have doubts regarding water quality please contact your local water authority or have a water test completed. In areas of poor water quality all major components will have a reduced life due to the hardness of the water. In areas with "hard water" (>200 mg/L or ppm), a water softening device must be installed to ensure the long term efficient operation of the system is met. Note that the Reclaim Energy glass-lined tank has a sacrificial anode to protect the vessel from corrosion. The glass line tank warranty is linked to an anode inspection that must be carried out every three (3) years.

### 6.1.1 COMPONENT INSPECTION

Prior to installation, please check that the following components have been provided. Any concerns must be brought to the attention of Reclaim Energy immediately.

- Heat pump unit
- Tank + PTRV
- Controller module
- Heat pump mounting frames (checked with a reseller)

#### NOTE

All other components required for the installation not listed here should be provided by the installer.

### 6.1.2 COMPONENT TRANSPORTATION

- When transporting boxes, note the orientation of the "THIS WAY UP" arrows.
- Ensure all boxes are strapped and secured to prevent movement during transit.
- All tanks must be transported upright. Stacking is not recommended for any tanks.
- Products should always be handled with care. Damage incurred during the transportation is not covered under product warranty.

### 6.1.3 UNPACKING OF THE COMPONENTS

- When unpacking, take care to ensure that the components are not damaged in the process.
- Avoid using sharp blades or knives as this can scratch the surfaces of the products.

## 6.2 HOT WATER STORAGE TANK

### 6.2.1 INSTALLATION LOCATION

- The storage tank must be installed at ground or floor level and must stand vertically upright as per the manufacturer guidelines.
- Tanks must be secured on a concrete or plastic mounting slab as shown in Figure 6.
- The storage tank should be located as close as possible to the most frequent draw off points in the building such as the bathroom or kitchen. If the storage tank is located a long way from hot water draw points, a hot water circulation loop on a timer may be considered to reduce the time-lag for water to reach the tap. Please note this is not supplied by Reclaim Energy but the installing plumber can consider installing a ring main system for hot water circulation.
- The tank should not obstruct any windows, doors or exits. Clearances must be provided to make servicing and maintenance convenient without the need for ladder or scaffold. For servicing, the PTRV must also be easily accessible.

- The tank should be positioned to allow room for anode removal.
- The storage tank must be installed in a properly drained safe tray if installed indoors where leakage may cause damage. The installation of the storage tank and safe tray must comply with AS/NZS 3500.4 and all local codes and regulatory authority requirements with regards to its construction, installation and draining. Tanks installed outside must be installed on a suitable concrete slab.
- The tank label must be clearly visible.

### 5.2.2 CONNECTIONS AND INSULATION

The piping diagram of storage tank with other components is given in Section 5.5. Note for the AP315AGLH (a Glass-lined enamel tank) model ID, the PTRV on the tank should be first removed initially and installed on a tee valve connection. For the rest of tank model IDs, NO tee valve connection is required. Connections will not be required on our glass-lined tanks shipped from 18th March 2020.



Figure 6: Concrete or heavy duty plastic slabs to be placed under the storage tank.

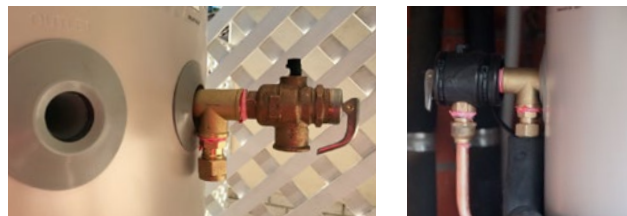

Figure 8: A tee connection for heat pump return line and PTRV valve (AP315AGLH model number only).



Figure 7: A photo of installed hot water system with proper insulation of pipelines.

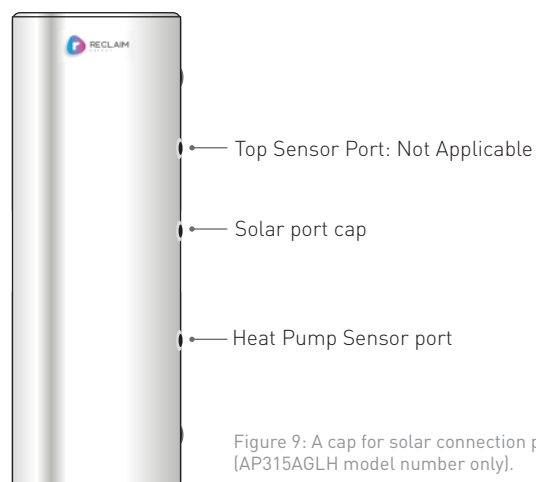

Figure 9: A cap for solar connection port (AP315AGLH model number only).

## INSTALLATION DETAILS CONT.

## 6.3 HEAT PUMP

Before plumbing and/or wiring of the heat pump unit and integration with the rest of the system, the following sequential steps must be conducted.

### 6.3.1 INSTALLATION LOCATION AND SPACING

- Be sure to install the heat pump unit horizontally on a flat surface.
- Be sure to install the heat pump unit in accordance with the spacing provided in Figure 10.

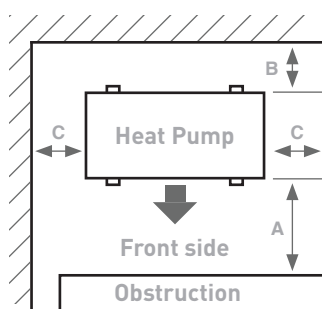

**Note 1:** PCB should be accessible for maintenance and installation

**Note 2:** Installation next to the air conditioning unit is approved as long as the exhaust of one unit is not absorbed by the other unit and the exhaust airs are not in contact with the piping.

Figure 10: Required space for installation of heat pump.

- A** 350mm and longer in case that the height of obstruction is below 1,200mm 600mm and longer in case that the height of obstruction is 1,200mm and higher
- B** 150mm and longer
- C** 150mm and longer

### 6.3.2 MOUNTING

Note Reclaim Energy ASHP **MUST** be installed on the ground with mounting frames that is a default supplied component **OR** on the wall with brackets. Note, a plumber needs to have access to the underneath of unit in order to service the unit and to complete the purge protocols.



Figure 11: Ground mounting frames.



Figure 12: Wall mounting brackets



Figure 13: A heat pump drain elbow plug supplied with heat pump unit.

### 6.3.3 ATTACHING THE DRAIN ELBOW PLUG

A drain plug is supplied in the bottom side of the heat pump unit box packaging as shown in Figure 13. Per schematic shown in Figure 14, safely connect the drain elbow and guide the drain hose to the ditch if required.

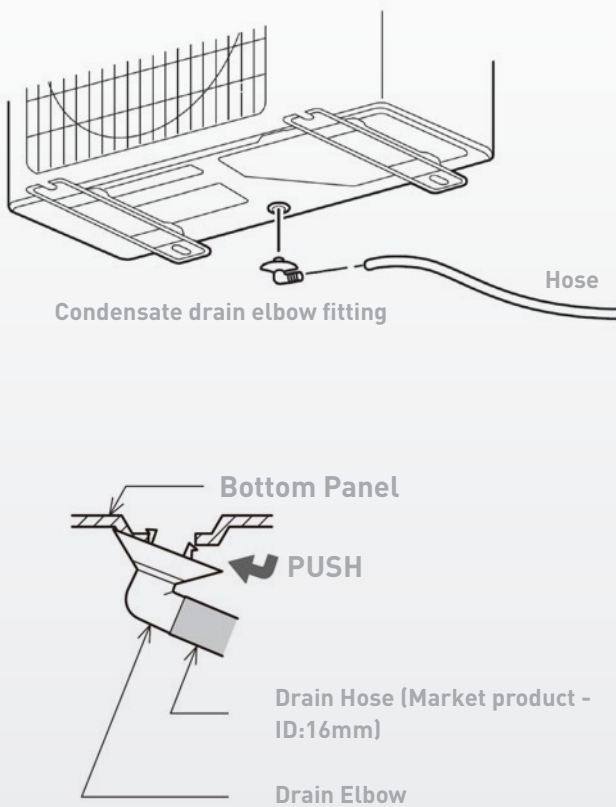

Figure 14: How to attach drain elbow.

### 6.3.4 REMOVING/ATTACHING THE PIPING COVER

#### REMOVAL

- 1 Remove the screw
- 2 Remove the piping cover sliding downward.

#### ATTACHMENT

- 1 Fit the piping cover to the unit adjusting 5 tabs.
- 2 Attach the piping cover sliding upward and fix it with the screw.

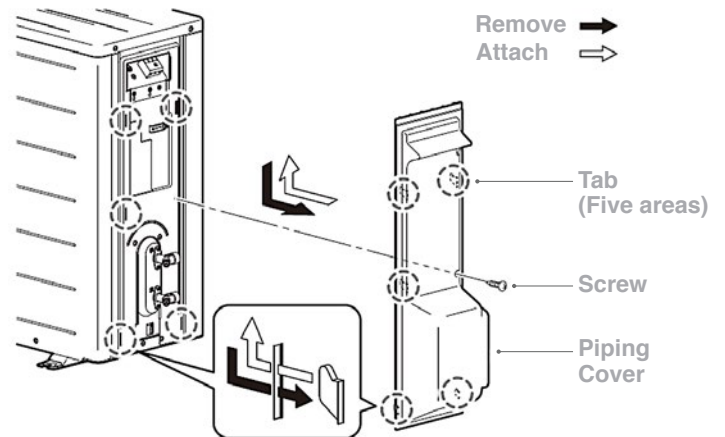

Figure 15: How to attach/detach the piping cover.

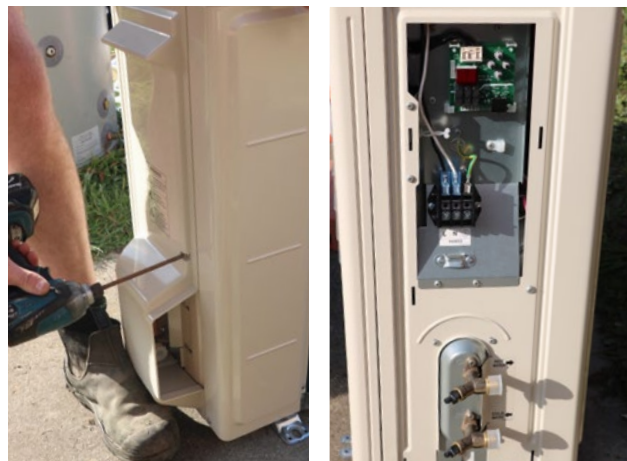

Figure 16: How to remove the piping cover from heat pump.

## INSTALLATION DETAILS CONT.

## 6.4 CONTROLLER

Please note that this controller has 4 cable grommets and glands as shown in Figure 17. The spare cable gland provided is not functional in this version of system. The power cable and sensor lead are already prewired, so the installer just needs to mount the controller on the tank. It is recommended that the installer follow the steps belows:

- 1 Mounting on the controller on the tank is the first recommendation. If this is not possible then the installer should find an alternate fixture for the control unit that is in close proximity to the storage tank and heat pump unit. Note that the controller should be wired to the power socket, the sensor socket on the tank, and the PCB board on the heat pump. The RJ cable and sensor lead are 10 and 2m long, respectively.

The controller box is waterproof, but **DO NOT** install the controller under the PTRV valve or where there is a risk of water leaking.

- 2 Open the controller lead, mount and screw it on the tank wall per instructions given in this section.
- 3 Attach another end of RJ45 cable to the heat pump PCB.
- 4 Attach the sensor lead to the sensor socket on the tank.
- 5 Plug in the power cable- but **ONLY** turn the power on after following the instructions of Section 6.5.

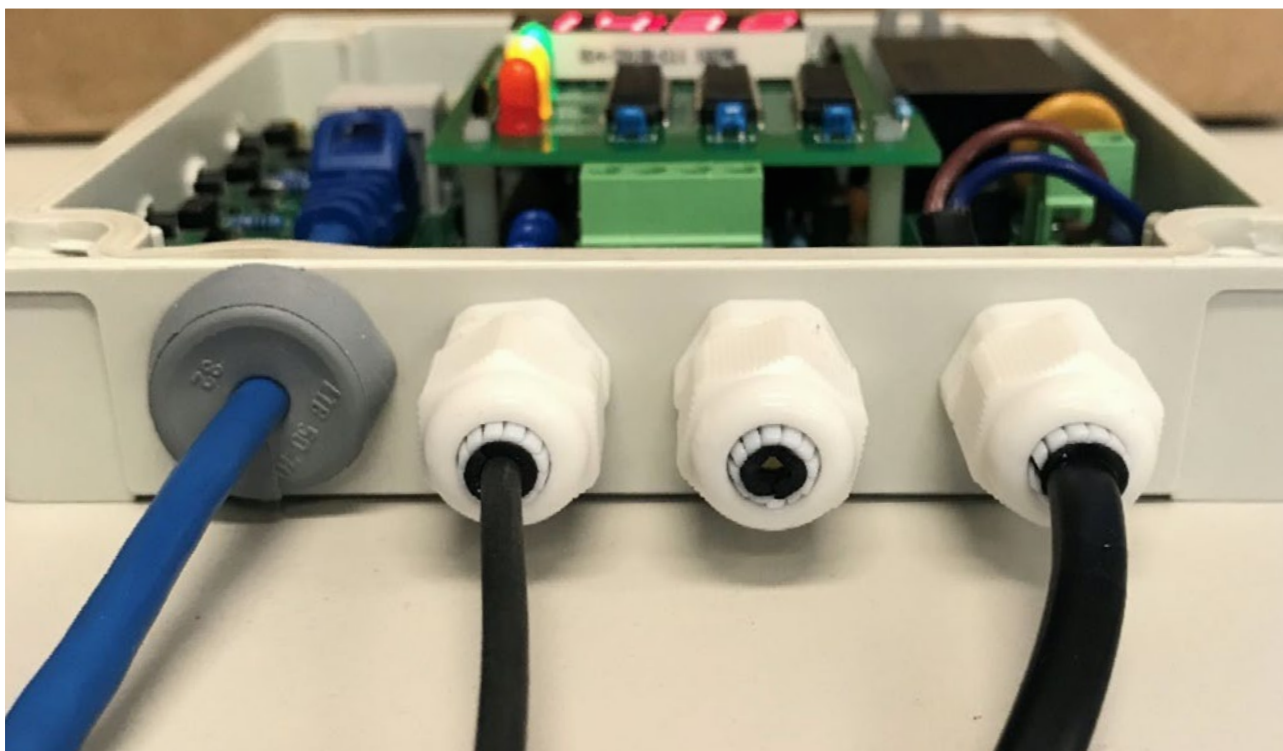

Figure 17: Cable grommet and cable glands (left: RJ45 cable, second left: tank sensor, third left: spare, right: power cable).

### 6.4.1 HOW TO MOUNT THE CONTROLLER ON THE TANK WALL

Using a Phillips head screwdriver remove the modules top cover by loosening the four cover screws and lifting off the cover and then follow the steps below (please refer to Figure 18):

- 1 Choose a suitable position on the tank.
- 2 Loosen the cover securing screws and remove the opaque cover.
- 3 Since the tank surface is curved, use the spacers provided using the 4 No. spacers and screws provided to mount the module to the skin of the tank.
- 4 Orientate the spacers so the wider base of the spacer touches the tank surface.
- 5 Secure with the self-drilling and tapping screws provided.

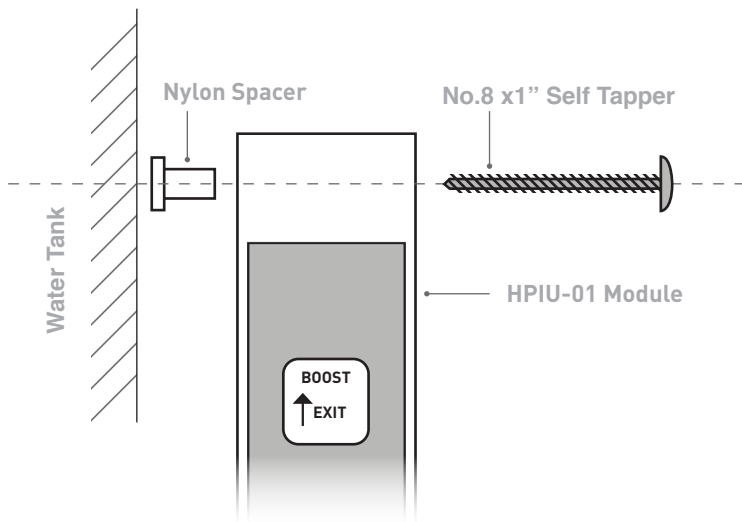

Figure 18: How to bolt a controller on tank surface.



Figure 19: A photo of an installed controller on the tank.

## INSTALLATION DETAILS CONT.

**6.4.2 TERMINAL BLOCKS- PREWIRED POWER CABLE AND SENSOR CABLE**

As the connections are prewired, the installer just needs to check if they are in place and tight enough. The 230v power cable is prewired to the terminal block CON1, as shown in Figure 20. Check the connections and tighten if necessary. Check to ensure the cable gland the power cable passes through is tight.

**CON1:**

A : Active conductor – Brown, N : Neutral conductor – Blue



Figure 20: Prewired power cable on terminal block 1 (CON1).

The RJ45 patch lead is pre-fitted to the module as shown in Figure 21. This lead provides the communication link to the Heat Pump Unit. Check the cable grommet to ensure it's in place (Figure 21) and the RJ45 plug is securely fitted in the socket on the circuit board. Note the patch lead is 5 m long and if required a longer lead can be purchased separately. The longest patch is recommended to be 15 m maximum and the RJ cable **MUST** be "RJ45 Patch cable".

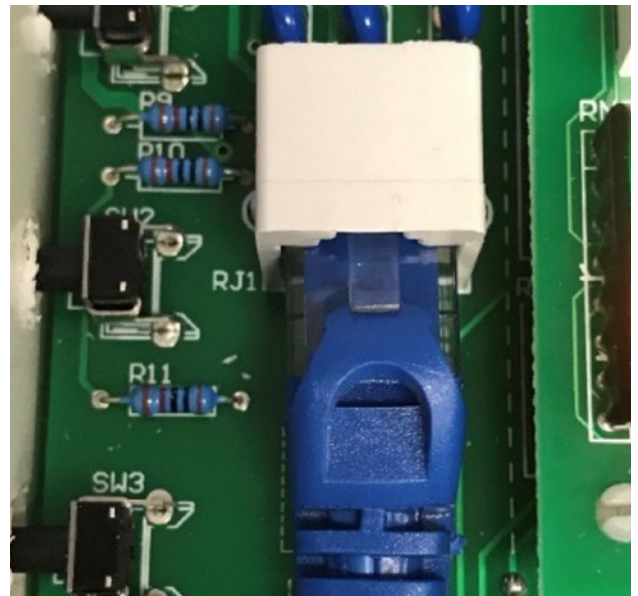

Figure 21: RJ 45 cable connection.

The Tank temperature sensor is prewired to the terminal block CON2, terminals 1 and 2 as shown in Figure 17. Check the connections and tighten if necessary.

**CON2:**

T1 – Temperature sensor white wire

T2 - Temperature sensor black wire



Figure 22: Storage tank terminals 1&2 on block 2 (CON2).

## 6.5 SYSTEM INTEGRATION AND COMMISSIONING

Licensed installers MUST follow the procedure below for the commissioning of the heat pump system. A licensed installer should install the system in line with the wiring and plumbing schematics provided in Figure 23 and Figure 26 in accordance with local/national building, plumbing, and wiring codes.

Insulate all pipes running to and from the heat pump with UV rated insulation of at least 15mm thickness, or 25mm in cold climates (where temperatures drop below freezing). Also, ensure the insulation is tight against the ports (minimising the loss of heat from any exposed areas).

A licensed plumber should install the system with regards to the plumbing schematic provided in Figure 23 and in accordance with local/national building and plumbing codes.

### 6.5.1 SYSTEM PIPING

For domestic installations, the recommended pipe is copper, with the following dimensions 1/2" / 12.7 mm.

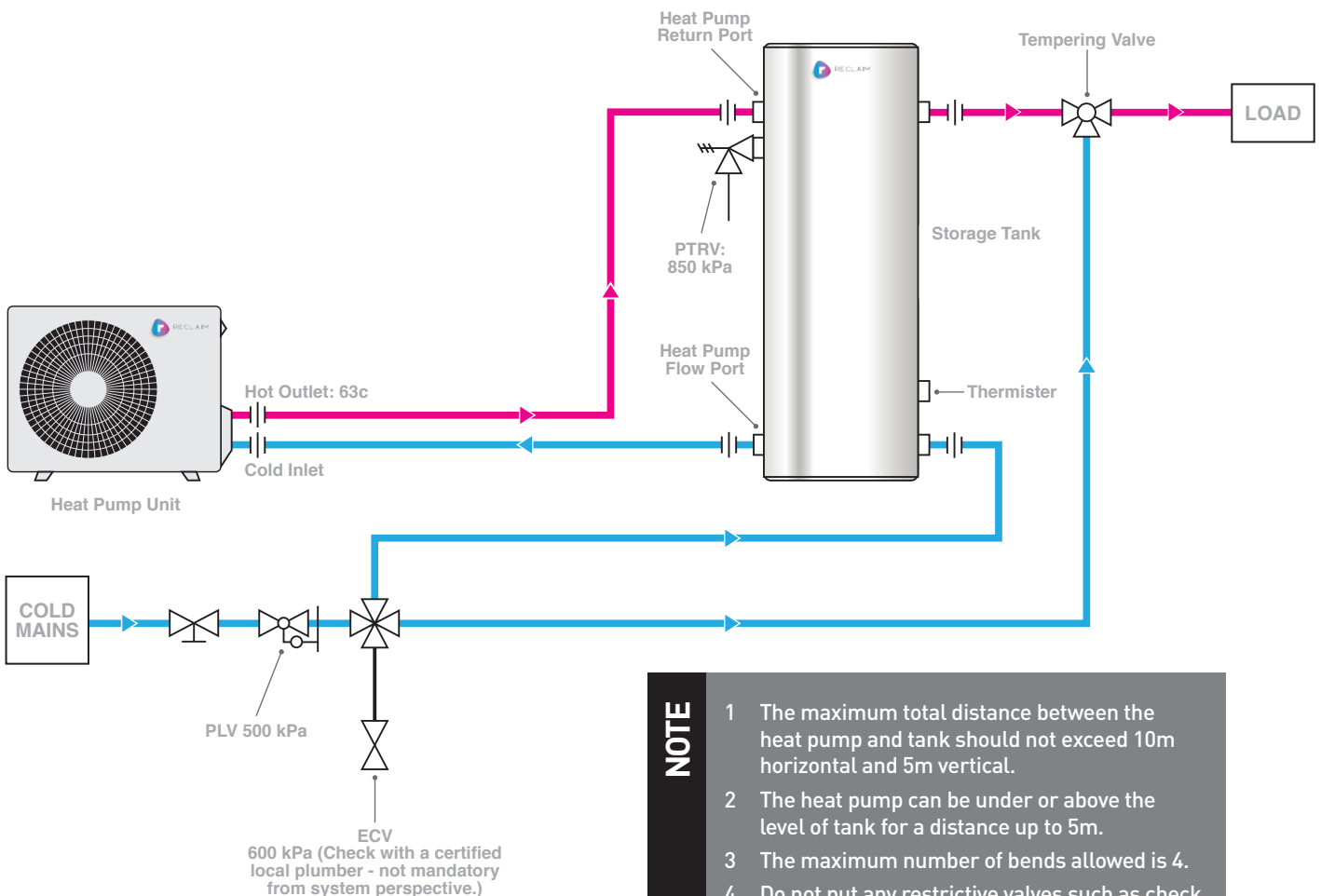

**NOTE**

- 1 The maximum total distance between the heat pump and tank should not exceed 10m horizontal and 5m vertical.
- 2 The heat pump can be under or above the level of tank for a distance up to 5m.
- 3 The maximum number of bends allowed is 4.
- 4 Do not put any restrictive valves such as check valves or strainers in the heat pump flow/return lines. This will void warranty and affect the units performance
- 5 A 20 A isolator switch is recommended to isolate the heat pump unit.
- 6 Sensors should be entirely pushed into the tank and tight up to the gland.

Figure 23: Plumbing diagram of Reclaim Energy ASHP hot water system.

## INSTALLATION DETAILS CONT.

**6.5.1.1 MAIN PRESSURE CONTROL OF THE SYSTEM**

Where the mains supply pressure can exceed or fluctuate beyond the pressure of 500kPa, a pressure-limiting valve must be fitted to the cold mains line. The device is installed after the duo valve (isolation valve and check valve) and should have a pressure limit of 500kPa.

If the property does not have the cold pressure inlet limited to 500 kPa (at the water meter), one **MUST** be fitted at the hot water service cold supply to prevent main pressure fluctuations blowing the PTRV. In some states it is a mandatory requirement that an expansion control valve be fitted on the cold mains line to provide a form of pressure relief. A separate drain line must be run for this relief valve (as per AS/NZS 3500). If unsure, please check with the local authority. Reclaim Energy recommends the use of an ECV=600 kPa on installation (if required by law in your state – check with your plumbing authority). See Figure 24 for details.

The mains line should consist of the following brass components when installing:

- Duo valve
- Cold Water ECV
- Pressure Reducing Valve
- Four-Way Cross

The set of mains line valves can be purchased as a kit from Reclaim Energy and provides the above components with insulating jackets to streamline the installation process.

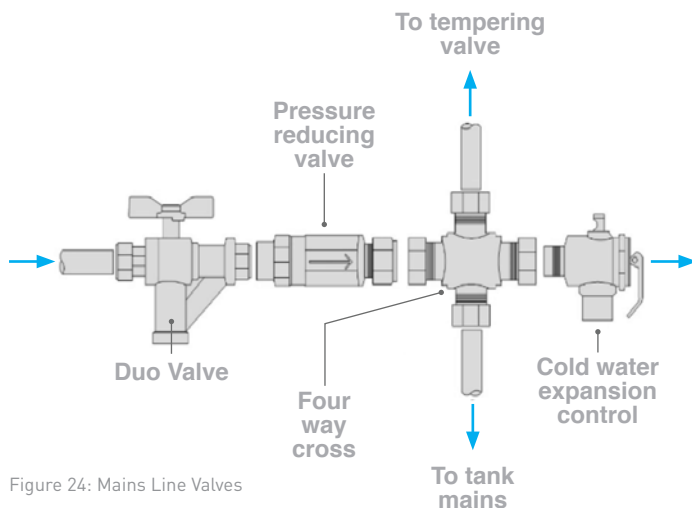

Figure 24: Mains Line Valves

**IMPORTANT**

The tempering valve must be the last downstream component installed before the hot water reaches the house.

### 6.5.1.2 HEAT PUMP WATER PIPING INSTALLATION

After removing the right side piping cover of heat pump unit, the heat pump cold (inlet) and hot (outlet) pipes (connection ports) will be accessible as shown in Figure 25.

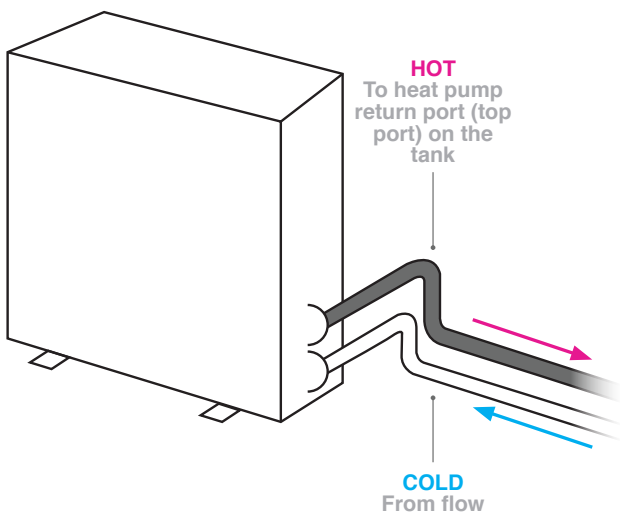
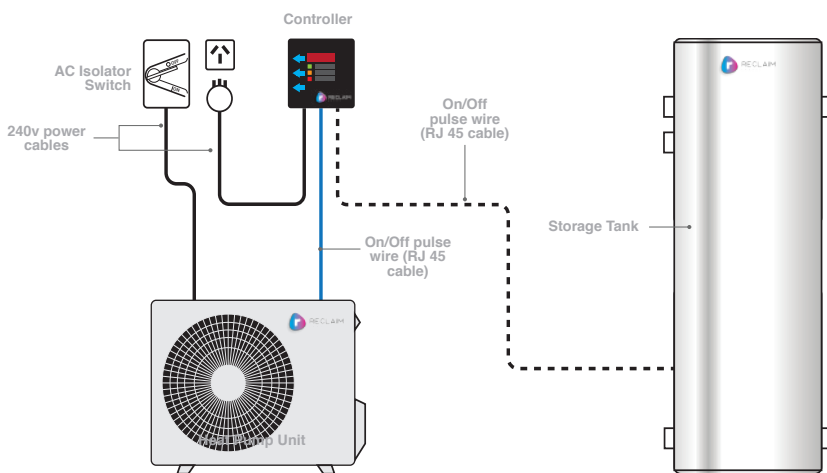

Figure 25 Connection of heat pump piping.

### 6.5.2 SYSTEM WIRING

A licensed electrician should install the system with regards to the wiring diagram provided in Figure 26 and in accordance with local/national wiring codes. The power cord chosen must be compliant with AS/NZS 3191 and the nominal cross-sectional area should be 1.5 mm<sup>2</sup> or more.



**IMPORTANT**

Do not supply power to the controller or heat pump unit before conducting the process explained in section 6.5.3 and 6.5.4.

Figure 26 Wiring diagram of Reclaim Energy ASHP hot water system.

INSTALLATION DETAILS CONT.

6.5.1.2 HEAT PUMP WATER PIPING INSTALLATION

After removing the right side piping cover of heat pump unit, the heat pump cold (inlet) and hot (outlet) pipes (connection ports) will be accessible as shown in Figure 25.

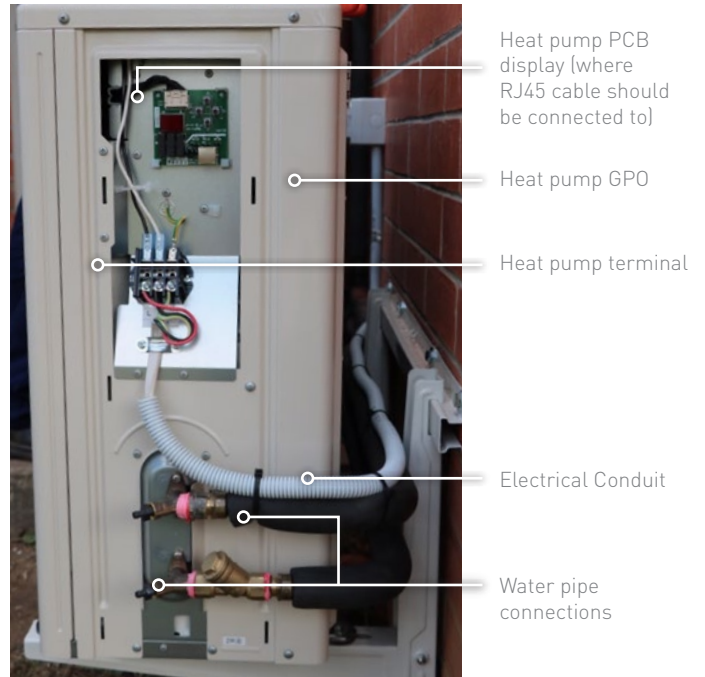

Figure 27: The wiring of power cord from heat pump terminal to the heat pump GPO.

The process of connecting the power cable to the heat pump terminal is shown in figures 28 & 29 below:

POWER SUPPLY TERMINAL BLOCK:

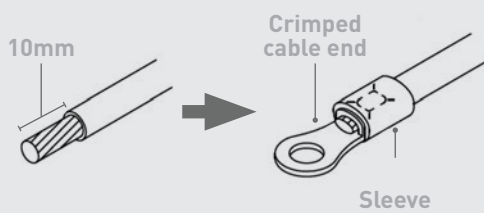

Figure 28: How to attach the power cable.

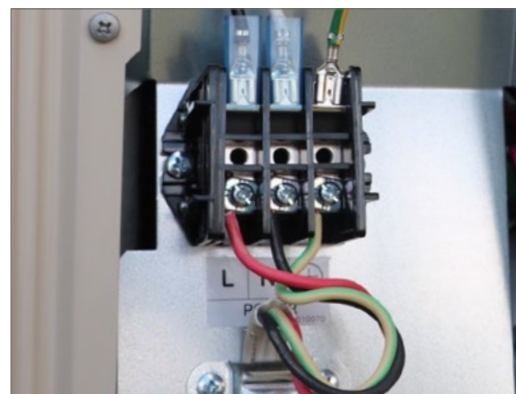
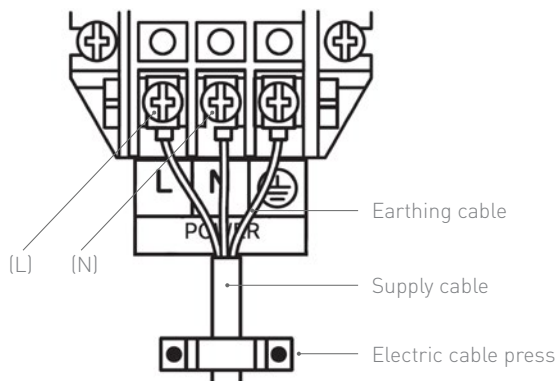
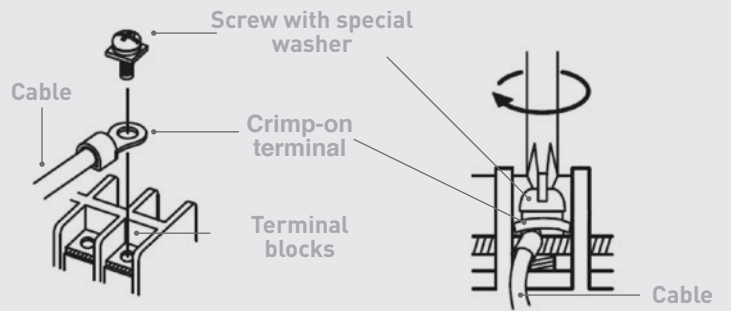

Figure 29: Attached location of power cable on heat pump terminal

### 6.5.3 POWERING UP THE CONTROLLER FOR THE FIRST TIME

When power is first applied to the controller, the following display sequence occurs.

1. "Init" is displayed, while the default settings are loaded into the clock memory.
2. " " display is blanked momentarily.
3. "88:88" and all LEDs turned on to check all display LEDs are functional.
4. " " display is blanked momentarily.
5. Time will be displayed.
6. If time is incorrect refer to clock settings to set correct time for your region.

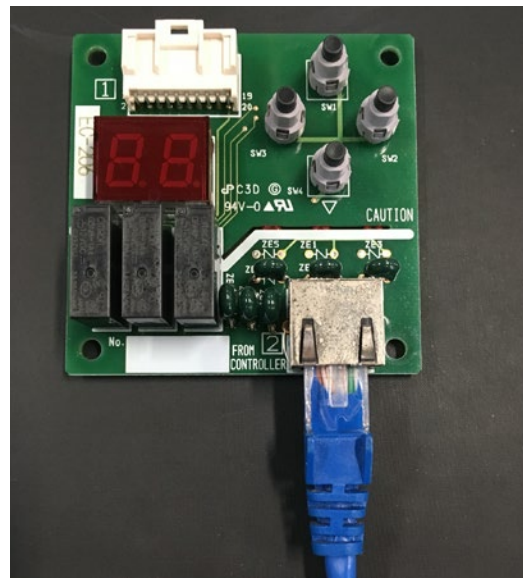
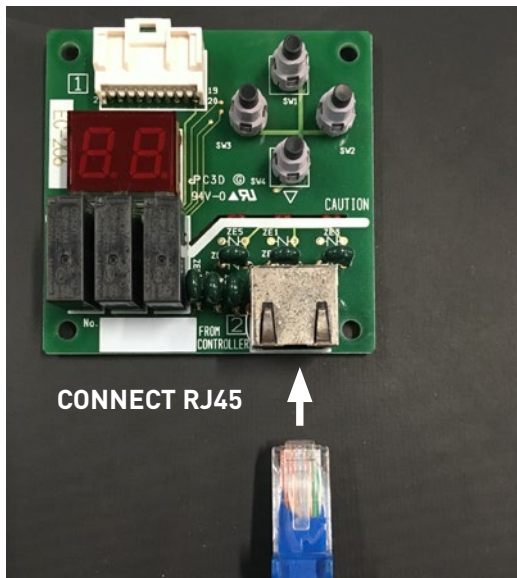

Figure 30: How to connect RJ45 PATCH cable to heat pump display unit.

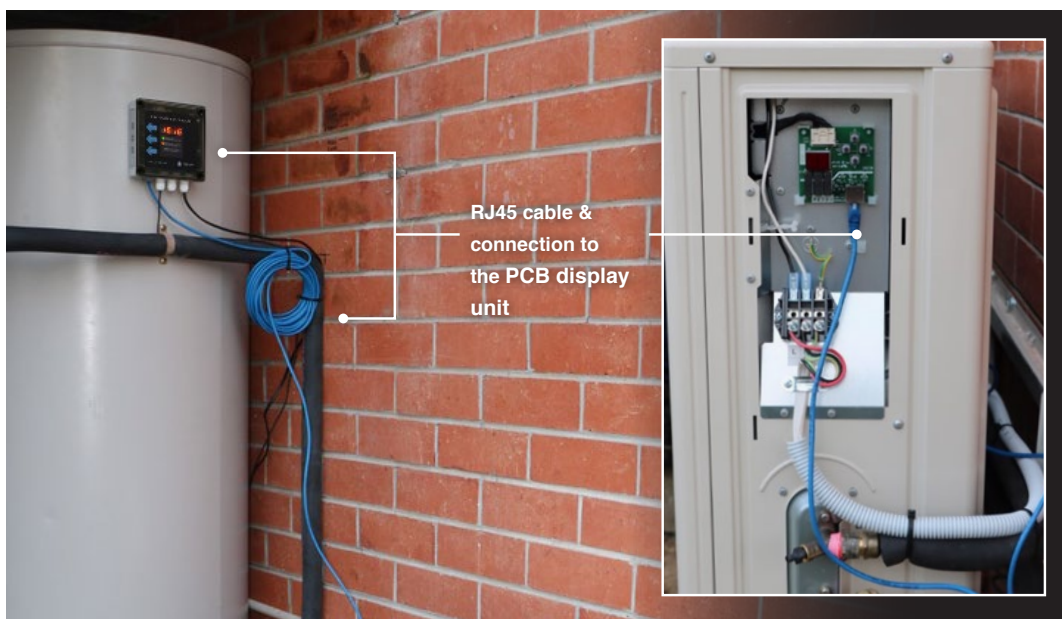

Figure 31: Wiring of RJ45 cable from controller to the PCB display unit.

## INSTALLATION DETAILS CONT.

**6.5.3.1 SETTING THE TIME OF DAY**

- 1 Press the Menu Button, "Menu" is displayed.
- 2 Press Temperature Button (move to next parameter), "TIME" is displayed.
- 3 Press the Menu Button, Time of day "XX:XX" is displayed, alternatively with "Adj-", indicating you are in data change or adjust mode).
- 4 Use the Boost Button to increment the Time UP, or the temperature button to decrement the Time DOWN. The longer the button is pressed the faster the time will change. Note that the "Adj-" prompt is not displayed whilst the up/down buttons are pressed.
- 5 Once the correct time of day is displayed, press the Menu button.
- 6 "TIME" will be displayed. Press the Boost button (exit) to revert to the normal display.
- 7 Note: If no button is pressed for 30 seconds, the display reverts back to Normal Display Mode.
- 8 Note that the clock is always in 24hr mode, and all adjustments for day light saving must be done manually.

**6.5.3.2 SETTING THE HEAT PUMP OPERATIONAL MODE**

There are 4 pre-set operational modes as well as a timer setting option (option 5) that is adjustable by the end users. The default setting of the controller is OPTION 1 which is 24/7 operational mode thermostatically controlled. In order to read about available options and make changes to default settings, please refer to the operational section of this manual for the controller in Section 6 of this manual.

**5.5.4 Powering of the heat pump AND air purge procedure**

Before first run of heat pump, the installer **MUST** complete a TWO-STEP purging process. This can be completed using the drain plug located under the heat pump unit, followed by running the purge mode operation by the controller.

**6.5.4.1 FILLING OF THE SYSTEM WITH HOT WATER AND AIR PURGE THE HEAT PUMP UNIT****CAUTION**

Make sure to complete the air purge before heating operation. It can cause unit failure.

Follow the air purge procedure of the system per below steps:

- 1 Fill the storage tank until water discharges through PTRV or tap inside building.
- 2 Close off the tap inside building or PTRV.
- 3 Pull PTRV slowly once more before purging heat pump unit to ensure the hot water tank is full and pressurized.
- 4 Loosen the drain plug that is shown in Figure 35 and discharge water till running free with no air spurts (20 seconds), and close the drain plug.
- 5 Supply the power to the heat pump unit.

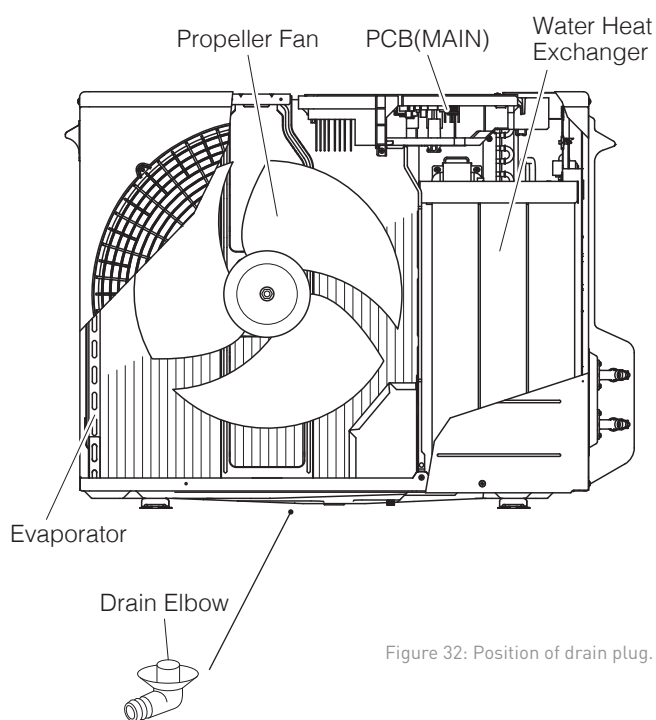

Figure 32: Position of drain plug.

### 6.5.4.2 HOW TO RUN THE PURGE MODE ON THE CONTROLLER

To activate Purge Mode, perform the following steps:

- 1 Ensure the module is in the Normal Display mode, displaying either Time of day, or Temperature.
- 2 Press and hold down the Menu button for approximately 5 seconds.
- 3 The Display will commence flashing "Purg".
- 4 The heat Pump output will be disabled.
- 5 The Purge output will be enabled.
- 6 Purge mode will remain active for 5 minutes.
- 7 All menu and display modes are disabled during Purge Mode.
- 8 After 5 minutes has elapsed, the purge output will turn off.
- 9 All control functionality will resume.
- 10 When the test operation display above disappears and the purge mode is complete, open the PTRV on tank for 5 seconds.
- 11 When water comes out from the PTRV on tank, close the PTRV.

Note: Purge mode can be turned off at any time, by pressing and holding the menu button for 5 seconds. Purge mode is automatically turned off if the module is currently displaying a heat pump error code.

## 6.6 POST INSTALLATION INSPECTION CHECKLIST

A licensed installer should check for the following before leaving the installation site.

System check: Check all connections for leaks and that all components are installed as per this manual.

Take photos of all system components for warranty purposes. This should include photos of the plumbing lines to and from the tank, heat pump and sensor port connection.

Note down the Tank Serial Number

Note down the heat pump Serial Number

Note down the controller Serial Number

Fill out the installation record form supplied for system warranty and service issues.

Submit your Installation Record Form via Email: [warranty@reclaimenergy.com.au](mailto:warranty@reclaimenergy.com.au)

Complete the rebate form for the system prior to leaving the site, this will require the installer's signature. Note this form is not supplied with us or in this document. This is responsibility of customers to have the rebate form ready for the installer to fill out.

# CHECKLIST

ITEM	CHECK
<b>GENERAL</b>	
Water supply is in accordance with water quality standard.	
There is no leakage from the pipes.	
There is no flammable hazardous materials around the unit.	
There is no damage, deformation or contamination to any components.	
There is enough space for inspection / repair of each component?	
The floor below the tank/heat pump has been properly water proofed and is capable of supporting the component.	
Hot water is available with enough pressure at the taps inside the house.	
<b>HEAT PUMP</b>	
The heat pump unit has been installed properly in line with these guidelines.	
The drain plug is properly closed	
The drain of heat pump unit is in the correct position to drain.	
A two-step air purge operation has been completed successfully.	
The wiring cover on the heat pump is correctly closed.	
<b>TANK</b>	
The operation of PTRV is normal.	
The tank unit is fixed in place with anchor bolts if necessary.	
<b>PIPING/WIRING</b>	
The mains breaker is of the correct size and voltage Breaker can be turned off, local disconnect is in place. The movement of circuit breaker is correct.	
Power supply wiring, ground wire, and "On/Off RJ45 cables" are fixed firmly.	
Union joints are used so that the parts can be easily removed.	
The insulation work for piping has been conducted properly.	
<b>CONTROLLER</b>	
Check all 3 connections are correctly firm and in place: 1- RJ45 Patch cable to heat pump unit, 2- Sensor cable to tank, 3- Power is connected.	
Correct time of day has been set up on the first powering.	
Controller operational mode (OPTION modes) has been set up with reference to the customer requirement.	

# OPERATION AND MAINTENANCE

The following section covers user guides and information on the day to day operation and maintenance of the Air-Source CO2 Heat Pump system.

## 7.1 CONTROLLER

### 7.1.1 DEFINITIONS AND CONTROL PHILOSOPHY

A photo of the controller module is shown in Figure 33. The module basically controls the “operational time” of the heat pump, by monitoring the temperature of the water in the storage tank. The “temperature control” turns the heat pump on at the T-on setting (37°C), and off at the T-off setting (59°C). On first start, the heat pump is turned on if the temperature is less than 59°C. On subsequent starts the heat pump is turned on when the temperature in the tank drops to the T-on setting (37°C) and turns off when the temperature reaches the T-off setting (59°C). The temperature control can also be enabled, or disabled during pre-set time periods (4 pre-set options) if required, or user selectable time periods (two available). A boost button is provided to enable the temperature control for a fixed 6 hourly period. The temperature button allows the user to quickly see the current tank temperature and briefly the currently set control option. To eliminate any possibility of legionella, the controller ensures the tank water temperature reaches 59°C at least once every 24 hours. The default display is time of day, in 24hr format. The controller display will display for time of day, temperature, error messages and menu items. There are also 3 status LEDs which are defined in Table 7: GREEN, AMBER, RED.

#### 7.1.1.1 TIME CONTROL MODE

The temperature control mode can be enabled and disabled during certain periods within the 24 hour cycle, as outlined in the options page. The user can select to permanently enable, four preset time periods or can opt for two fully adjustable time periods. When the Time Control Mode is active the Power ON LED flashes.

#### 7.1.1.2 TEMPERATURE CONTROL MODE

The “temperature control” turns the heat pump on at the T-on setting (37°C), and off at the T-off setting (59°C). On first start, the heat pump is turned on if the temperature is less than 59°C. On the subsequent starts the heat pump is turned on when the temperature in the tank drops to the T-on setting (37°C) and turns off when the temperature reaches the T-off setting (59°C).

#### 7.1.1.3 BOOST MODE

The Boost mode can also be turned on and off via a momentary press of the boost button. When activated, temperature control mode is enabled, as above, allowing the heat pump to turn on. The heat pump will remain on until the temperature reaches 59 °C, or the 6 hour period has elapsed, whichever occurs first. After the one-shot boost is complete, the controller reverts back to the last programmed setting.

**Important Note:** Temperature control mode is disabled if a faulty temperature sensor is detected (Eg-8 and Eg-9), although the boost mode is still operational.

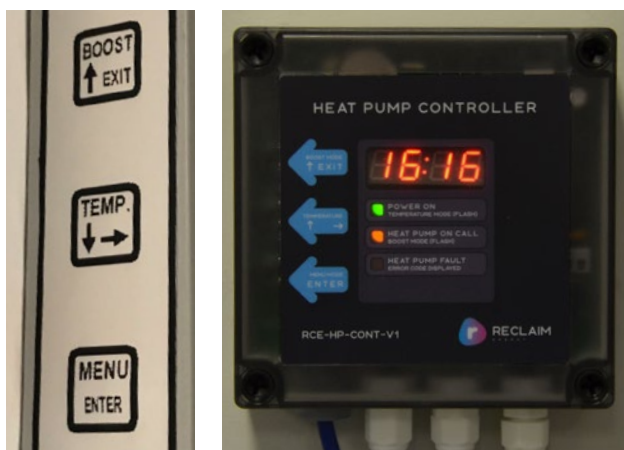

Figure 33: A photo of controller module: side buttons (left), front panel (right)



LED	LED ON - SOLID	LED ON - FLASHING
	Power On	Temperature Mode Enabled
	Heat Pump on Call	Heat Pump in boost Mode
	Heat Pump Fault	Temperature Sensor Fault

Table 7: Definition of status LEDs.

## OPERATION AND MAINTENANCE CONT.

**7.1.1.4 LEGIONELLA TIME CYCLE CHECK**

For the effective elimination of Legionella, the system control will automatically heat the temperature of 59°C at least once every 24 hours.

**7.1.2 DETAILS OF OPERATIONAL MODES**

The temperature mode can be enabled by various time switch modes. These are selectable in the 'User Menu'. Whenever the temperature mode is enabled by one of these options, the Power ON LED will flash. Details of options are given in Table 8.

**IMPORTANT**

On the first activation (within a 24 hour time cycle), the Heat Pump will run until the turn OFF temperature is reached, regardless of the turn OFF time setting. On all subsequent activation (within a 24 hour time cycle), the Heat Pump operates in temperature control mode, switching between the temperature ON & OFF thresholds. When the OFF time is reached, temperature control mode is disabled, and the Heat Pump is turned OFF, regardless of the current tank temperature

SELECTABLE OPTIONS	DESCRIPTION
<b>Option 1 (pre-set)</b>	Temperature mode is enabled permanently (24hours). The heat pump will switch on when the temperature drops to the turn on temperature and switch off when the temperature reaches the turn off temperature.
<b>Option 2 (pre-set)</b>	Off-peak 1 (OP1): Temperature Mode is enabled at 2200 hours (10pm) and remains enabled for a period of 9 hours.
<b>Option 3 (pre-set)</b>	Off-peak 2 (OP2): Temperature Mode is enabled at 00:00 hours (12am) and remains enabled for a period of 6 hours. (12 am to 6am).
<b>Option 4 (pre-set)</b>	Temperature Mode is enabled at 1000 hours (10am) and remains enabled for a period of 6 hours. This mode is primarily used for P.V. connectivity.
<b>Option 5 (timer)</b>	This is a User selectable time switch mode, where you can select one or two starting times and the enabled heating periods (1-24 hours). If User 2 run time is set to zero, then User 2 mode is disabled.

Table 8: Details of selectable options for the operation of heat pump.

**7.1.3 FUNCTIONALITY OF SIDE BUTTONS**

Three push buttons are available as description in Table 9.



BUTTON	NORMAL MODE	MENU MODE	DATA CHANGE MODE
	Boost ON/OFF	Menu Exit	Increment Up
	Temperature Display	Move to Next Parameter	Decrement Down
	Menu Mode	Enter	Accept

Table 9: Controller side button functionality

### BOOST BUTTON:

Press to switch Heat Pump into boost mode. The On Call LED will start flashing, indicating the heat pump has been turned on via Boost Mode. If inadvertently pressed, boost mode can be turned off by pressing the Boost button again. After one-shot boost is complete, the controller reverts back to the last programmed setting.

### TEMPERATURE BUTTON:

Press to display current tank temperature (latches on for 20 sec). The current control option is also briefly displayed- refer to menu details for other functionality. The current "tank temperature" and "active operational option" can be read by pressing this button. The

temperature is displayed for 4 seconds (Figure 34), then the currently selected user option is displayed for 4 seconds (Figure 34), before reverting back to the tank temperature for a remaining 12 seconds. Note that this feature is disabled whilst in Menu Mode, during Purge Mode and whilst displaying a heat pump fault code or temperature sensor fault.



Figure 34: Sample display of controller: tank temperature (left) and active option (right).

### MENU BUTTON:

Refer to menu details given in Figure 35 for all functionality. Using Menu button, user can get access to setting of time of day, options, and system status. Figure 35 will be discussed in details in the next subsection.

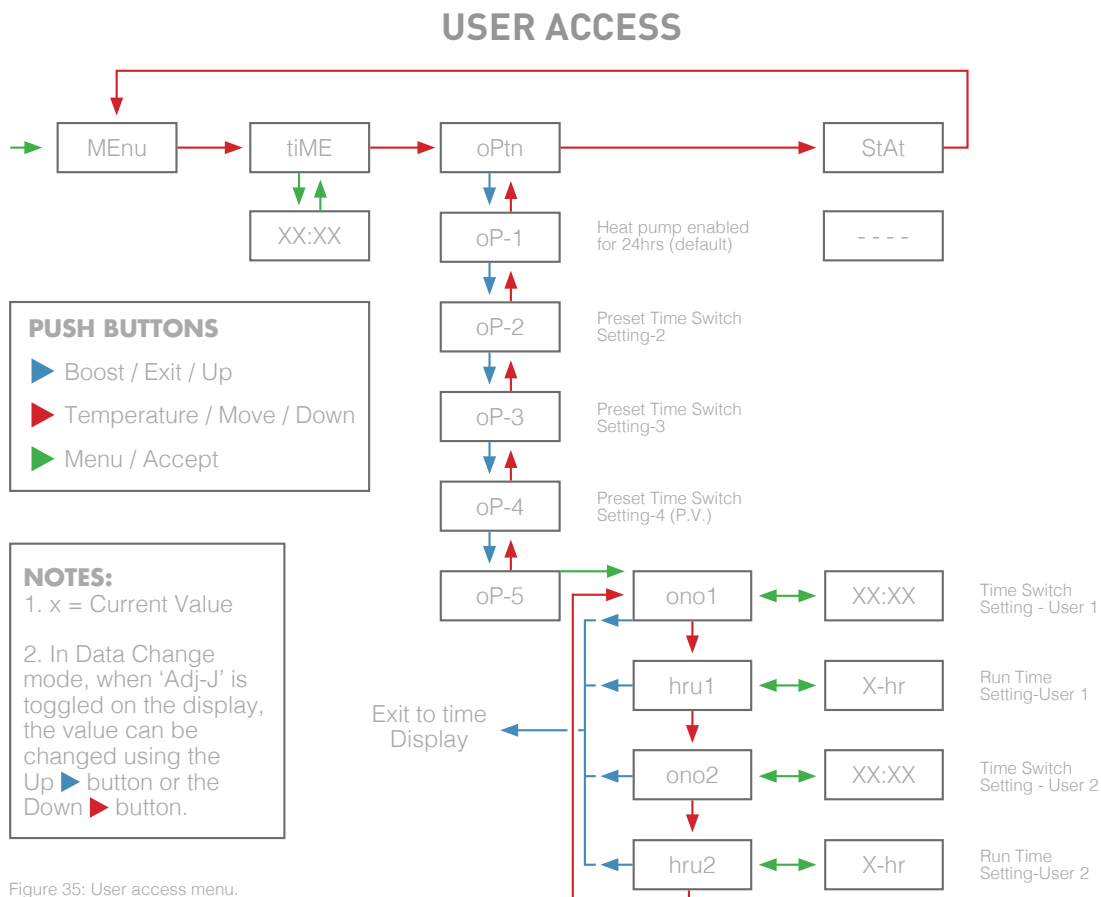

Figure 35: User access menu.

## OPERATION AND MAINTENANCE CONT.

### 7.1.4 USER MENU

There are three push buttons on the side of the module. Each button has multi functions depending on the menu level you are currently in. The menu can be stepped through as detailed above.

Pressing the "Menu" button enters menu mode (green arrow).

Pressing the "Temperature" button steps through each parameter (red button).

TIME: OPTN: STAT:

To adjust the Time of day.

To adjust the control options.

To display the current status of the remote control input and control latch.

### 7.1.5 SETTING THE CONTROL OPTION

With reference to the Menu Structure, carry out the following steps.

- 1 Press the Menu Button, "Menu" is displayed.
- 2 Press Temperature Button (move to next parameter), "TIME" is displayed.
- 3 Press Temperature Button (move to next parameter), "OPTn" is displayed.
- 4 Press the Menu Button, Option currently set "OP-X" is displayed, alternatively with "AdJ-", indicating you are in data change or adjust mode).
- 5 Use the Boost Button to increment the Option UP, or the temperature button to decrement the Option DOWN). Note that the "AdJ-" prompt is not displayed whilst the up/down buttons are pressed.
- 6 If setting the Option 1 to 4, then press "Menu" to return to the main menu loop, then press the Boost button to exit menu mode and return to normal mode.
- 7 If the Option is set to option 5, then this is the User Selectable time switch settings. Press "Menu" to enter User Time-ON-1, "onu1" is displayed.
- 8 This is the time of day you want the heat pump temperature mode enabled.
- 9 Press Menu button to display the current time-On setting. The "AdJ-" prompt will again appear.
- 10 Use the Boost Button to increment the Time-ON UP, or the temperature button to decrement the Time-ON

DOWN). The longer the button is pressed the faster the time will change. Note that the "AdJ-" prompt is not displayed whilst the up/down buttons are pressed.

- 11 Once the correct time-ON is displayed, press the Menu button to Accept.
- 12 Press the Temperature button to move to the User Hours-Run-1, "hru1" is displayed.
- 13 Press Menu button to display the current Hours Run setting. The "AdJ-" prompt will again appear.
- 14 Use the Boost Button to increment the Hours Run UP, or the temperature button to decrement the Hours Run DOWN). The longer the button is pressed the faster the time will change. Note that the "AdJ-" prompt is not displayed whilst the up/down buttons are pressed.
- 15 Once the correct Hours Run is displayed, press the Menu button to accept.
- 16 A second user selectable time switch setting is also available. Press the Temperature button to move to the User Time-ON-2, "onu2" is displayed. Repeat steps 9 to 11 to adjust, but if not required move to the next step.
- 17 Press the Temperature button to move to the User Hours-Run-2, "hru2" is displayed.
- 18 Press Menu button to display the current Hours Run setting. The "AdJ-" prompt will again appear.
19. Use the Boost Button to increment the Hours Run UP, or the temperature button to decrement the Hours Run DOWN). The longer the button is pressed the faster the time will change. Note that the "AdJ-" prompt is not displayed whilst the up/down buttons are pressed. If the second user selectable time switch is not required, it can be disabled by setting the user hours run-2 period to 00 hrs.
- 20 Once the correct Hours Run is displayed, press the Menu button to accept.
- 21 Once finished, simply press the Boost button (exit) to revert to the normal display or wait 30 seconds for auto exit.

### 7.1.6 POWERING UP THE MODULE (REPEAT TIMES)

- 1 "HP2d" is displayed, this is the current software version loaded.
- 2 " " display is blanked momentarily.
- 3 "88:88" and all LEDs turned on to check all display and status LEDs are operating.

- 4 " " display is blanked momentarily.
- 5 "XX:XX" Time of day is then displayed. Module is now fully operational.
- 6 Whether the Heat Pump turns on is dependent on the current Control Option Setting, the current tank temperature, and the current time of day.
- 7 The On Call LED will turn on if the heat pump is activated.
- 8 The tank temperature can be displayed by pressing the temperature button momentarily. "XXoC" will be displayed for 4 seconds, the set controller option for 4 seconds before reverting back to the tank temperature for a further 12 seconds.

### 7.1.7 ERROR CODES AND TROUBLESHOOTING

Should the heat pump unit go into fault mode, it will generate a fault code which this module will display. The Fault LED will turn on, and one of the error code categories on Table 10 will be displayed. It is noticeable that each error code on the external controller has been synced with a corresponding fault condition on the heat pump PCB board where more details can be obtained on the heat pump PCB display. When an error is showing on the external controller, the piping cover on the left side of heat pump needs to be removed in order to get access to the heat pump PCB display.

ERROR CODE ON DISPLAY OF EXTERNAL CONTROLLER	DESCRIPTION
Eg-1	Heat Pump Sensor error
Eg-2	Compressor error or Refrigerant shortage
Eg-3	PCB error
Eg-4	Circulation failure
Eg-5	Pump error
Eg-6	Fan Motor error
Eg-7	Discharge temperature error
Eg-8	Tank Temperature sensor not detected (open circuit)
Eg-9	Tank Temperature sensor fault (short circuit)

Table 10: Error code categories on the external controller

## IMPORTANT

- 1 If tank is cold and no hot water available at taps after a consecutive 24-hour cycle and no error codes on display, this is a symptom for a faulty RJ45 PATCH cable. The connections for this cable should be checked at its two ends (on the controller and on the heat pump PCB board) or replaced before conducting more diagnosing.
- 2 Temperature control mode is disabled for Eg-8 and Eg-9 faults, however boost mode is still operational.
- 3 Eg-8 and Eg-9 faults have a fixed 3 second time delay for both fault on and fault off occurrences. Details of error codes and the procedure of trouble-shooting is summarized in Table 11. ONLY a licensed installer should conduct the troubleshooting process per instructions given in the "Service Manual".

## OPERATION AND MAINTENANCE CONT.

## ERROR CODE TABLE

ERROR CODES		APPEARANCE, PORTION, PARTS SEEMED WRONG		METHOD OF CHECK	TROUBLESHOOTING	ERROR RESET
REMOTE CONTROL	PCB					
Eg-1	H9	Outdoor temp. sensor error	Outdoor temp. sensor	Check the resistance value by tester.	Sensor should be replaced if it is broken.	Auto
			PCB(Main)	-	PCB (Main) should be replaced.	
	HC	Outgoing water temp. sensor error	Outgoing water temp. sensor	Check the resistance value by tester.	Sensor should be replaced if it is broken.	Auto
			PCB(Main)	-	PCB (Main) should be replaced	
	J3	Discharge temp. sensor error	Discharge temp. sensor	Check the resistance value by tester.	Sensor should be replaced if it is broken.	Auto
			PCB(Main)	-	PCB (Main) should be replaced.	
	J5	Suction temp. sensor error	Suction temp. sensor error	Check the resistance value by tester.	Sensor should be replaced if it is broken.	Auto
			PCB(Main)	-	PCB (Main) should be replaced.	
	J6	Defrost temp. sensor error	Defrost sensor error	Check the resistance value by tester.	Sensor should be replaced if it is broken.	Auto
			PCB(Main)	-	PCB (Main) should be replaced.	
	J8	Return water temp. sensor error	Return water temp. sensor	Check the resistance value by tester.	Sensor should be replaced if broken.	Auto
			PCB(Main)	-	PCB (Main) should be replaced	
Eg-2	E6	Start-up failure of compressor	Compressor connector	Check the connection of compressor connector.	Once checked, restart the HP unit.	Power OFF
			PCB or HP unit	-	PCB (Main) should be replaced. If the problem is not solved, HP unit should be replaced.	
	H6	Abnormal revolution of compressor	Drop of power voltage	Check the power voltage.	Check the power voltage.	Power OFF
			Heating water circulation circuit	Check if there are any conditions to block water flow such as clogging, air entrainment, or scale precipitation.	Once checked, restart the HP unit.	
			Each sensor	Check the resistance value by tester.	Sensor should be replaced if broken.	
			Heating pump error	Touch the pump to check if it operates or not.	Pump should be replaced if broken.	
			Expansion valve coil	Check the disconnection or short circuit.	Expansion valve coil shall be replaced if there is a disconnection or short circuit.	
			PCB or HP unit	-	PCB (Main) should be replaced. If the problem is not solved, HP unit should be replaced.	
	U0	Stop by detecting gas leakage	Discharge temp. sensor	Check the resistance value by tester.	Sensor should be replaced if broken.	Power OFF
			Expansion valve coil	Check the disconnection or short circuit.	Expansion valve coil shall be replaced if there is a disconnection or short circuit.	
			PCB (Main) or HP unit	-	PCB (Main) should be replaced. If the problem is not solved, HP unit should be replaced.	
	Eg-3	E1	PCB failure	PCB	Reset power supply.	PCB (Main) should be replaced if the problem is not solved.
E8		Stop by detecting input overcurrent	Drop of power voltage	Check the power voltage.	Check the power voltage.	Power OFF
			Installation condition	Check the installation condition of HP unit. (blocked air inlet port)	(blocked air inlet port) Change the installation position to keep the air inlet port area not blocked.	
			Each sensor	Check the resistance value by tester.	Sensor should be replaced if broken.	
			Heating pump error	Touch the pump to check if it operates or not.	Pump should be replaced if broken.	
			Expansion valve coil	Check the disconnection or short circuit.	Expansion valve coil should be replaced if there is a disconnection or short circuit.	
			PCB (Main) or HP unit	-	PCB (Main) should be replaced. If the problem is not solved, HP unit should be replaced.	

Table 11: Details of error codes on external controller and heat pump PCB display and troubleshooting process

CONTINUES ON NEXT PAGE...

ERROR CODES						
REMOTE CONTROL	PCB	APPEARANCE, PORTION, PARTS SEEMED WRONG		METHOD OF CHECK	TROUBLESHOOTING	ERROR RESET
Eg-3	H8	Current detection error	PCB(Main)	Reset power supply.	PCB (Main) should be replaced if the problem is not solved.	Power OFF
	L4	Module temperature error(90°C or higher)	Installation condition	Check the installation condition of HP unit. (blocked air inlet port)	Change the installation position to keep the air inlet port area not blocked.	Power OFF
			finned heat exchanger (for air)	Check if there are any spots on the fin or not.	Once checked, restart the HP unit.	
			Fan motor	Check if there are any foreign substances to block the fan motor or not.	If the problem is not solved, fan motor should be replaced.	
			PCB(Main)	-	PCB (Main) should be replaced.	
	L5	Detecting output overcurrent	Discharge temp. sensor	Check the resistance value by tester.	Sensor should be replaced if it is broken.	Power OFF
			Expansion valve coil	Check the disconnection or short circuit.	Expansion valve coil should be replaced if there is a disconnection or short circuit.	
			PCB (Main) or HP unit	When reset power supply, compressor repeats start and stop.	PCB (Main) should be replaced. If the problem is not solved, HP unit should be replaced.	
	P4	Module sensor error	PCB(Main)	Reset power supply.	PCB (Main) should be replaced if the problem is not solved.	Auto
	U2	Power voltage error	Drop of power voltage	Check the power voltage.	Check the power voltage.	
PCB(Main)			Reset power supply.	PCB (Main) should be replaced if the problem is not solved.	Power OFF	
Eg-4	HJ	Water Circulation system failure	Heating water circulation circuit	Check if there are any conditions to block water flow such as clogging, air entrainment, or scale precipitation.	Once checked, restart the HP unit.	Power OFF
			Each sensor	Check the resistance value by tester.	Sensor should be replaced if it is broken.	
			Expansion valve	Check the disconnection or short circuit.	Expansion valve coil should be replaced if there is a disconnection or short circuit.	
			PCB (Main) or HP unit	-	PCB (Main) should be replaced. If the problem is not solved, HP unit should be replaced.	
	EC	Stop by outgoing water temperature error	Heating water circulation circuit	Check if there are any conditions to block water flow such as clogging, air entrainment, or scale precipitation.	Once checked, restart the HP unit.	Power OFF
			Outgoing water temp. sensor	Check the resistance value by tester.	Sensor shall be replaced if it is broken.	
			Heating pump	Check if heating pump is operating by touching it.	If heating pump is broken, it is necessary to replace it.	
			PCB (Main) or HP unit	-	PCB (Main) should be replaced. If the problem is not solved, HP unit should be replaced.	
Eg-5	E9	Heating pump error	Tank	Check if water in the tank is full capacity level.	Once checked, conduct test operation for air purge again.	Power OFF
			Heating pump error	Check the number of rotation of heating pump on the PCBdisplay.	Heating pump and PCB (Main) should be replaced if heating pump is not rotated. Heating pump should be replaced if the rotation of heating pump is clearly low. PCB (Main) should be replaced if the rotation of heating pump is normal and E9 error is displayed.	
			PCB(Main)			
Eg-6	E7	Outdoor fan lock	Fan motor	Check if there are any clogging around fan motor or contact failures of connector.	Improve the cause of problem. If the problem is not solved, fan motor shall be replaced.	Power OFF
			PCB(Main)	Other than described above	PCB (Main) shall be replaced.	
Eg-7	F3	Stop by Discharge temperature error	Discharge temp. sensor	Check the resistance value by tester.	Sensor shall be replaced if it is broken. If sensor has no problem, expansion valve coil shall be replaced.	Power OFF
			Expansion valve coil	Check the disconnection or short circuit.	Expansion valve coil shall be replaced if there is a disconnection or short circuit.	
			PCB (Main) or HP unit	Other than described above	PCB (Main) shall be replaced. If the problem is not solved, HP unit shall be replaced.	
Eg-8	-	No detection of tank sensor	Tank sensor	Please contact Reclaim Energy Support on: 1300 38 38 15	Improve the cause of problem, then restart the HP unit.	Auto
Eg-9	-	Tank sensor failure	Tank sensor	Please contact Reclaim Energy Support on: 1300 38 38 15	Sensor shall be replaced if it is broken.	Auto

## OPERATION AND MAINTENANCE CONT.

## 7.2 HOT WATER STORAGE TANK

### 6.2.1 PTRV

Any system design must allow a means of pressure release at no more than 850kPa, using a PTRV. The PTRV must have a downward direction copper pipe connected that is open to the atmosphere, running the expelled hot water or air to a safe, frost free and appropriate drainage location. From time to time the PTRV may discharge small amounts of water under normal operations (1L for every 50 Liters heated). If the tank is installed indoors, a safe-tray must be installed beneath the hot water tank to safely collect any water expelled from the PTRV.

### 7.2.2 ANODE

The anode on your Glass lined (vitreous enamel) tanks is sacrificial, however it is designed to protect the vitreous enamel lined cylinder in most public reticulated water supplies for five years after which time it should be replaced as part of an annual service. It must be noted however that many water supplies can exhibit chemical qualities that are not suitable for the standard anode supplied with glass-lined water heater. Where the Total Dissolved Solids (TDS) is greater than 600mg/L or less than 40mg/L, the installed anode may be unsuitable for use to protect your water heater. In these circumstances, a plumber or authorized service person should be contacted to fit the correct (hard water) anode. Please note that warranty becomes void if the TDS value exceeds 2500 mg/L.

### 7.2.3 HYDROGEN BUILD UP

Glass lined (vitreous enamel) tanks are fitted with a Magnesium anode to provide corrosion protection for the tank from the storage water. Small quantities of hydrogen gas can be released by the anode, which generally remains dissolved in the water and flushed away as hot water is used from the tank. Depending on the water quality there may be a degree of hydrogen build-up in the tank if the water heater hasn't been used for two or more weeks or if water appears milky in color. To resolve the build-up of hydrogen within the tank, "purge" the tank for approximately 30 seconds from the lever on the PTRV. Stand clear of PTRV discharge piping outlet.

## WARNING

Ensure there are no open flames or ignition sources close to the tank.

## 7.3 HEAT PUMP UNIT

### 7.3.1 HOW TO DRAIN THE SYSTEM DRAINAGE FOR THE SYSTEM:

- 1 Turn off the power.
- 2 Close the main water valve.
- 3 Open the relief valve
- 4 Disconnect cold supply to the tank and drain from connection fittings to tank if no drain is fitted on the tank. Open the drain valve of the tank.
- 5 After checking there is no water coming out from the tank, close the drain valve of the tank and open the drain plug of the heat pump unit (Figure 29).
- 6 When checking there is no water coming out from the heat pump unit, close the drain plug (Ref : Figure 29).
- 7 Close the relief valve.

## 7.4 MAINTENANCE CHECKLIST FOR THE OWNER

The first indication that your system may have an operational issue is of course lack of hot water in the household. There might be a few reason for this which includes an issue with the installation, a system error and/or the settings of the controller, to name but a few. For any system related issue, the owner first needs to check the controller for any sign of error codes. If there is no error code, one way to make sure that there is always enough hot water is place the system operational mode on OPTION 1 which guarantees the maximum hot water generation for the unit.

Failing to maintain the system per the specifications stated in the installation manual and more specifically in the maintenance section will void the warranty.

- Check the controller status: (min) once per week and see if any error codes displayed. If the yellow light is flashing, call Reclaim Energy on 1300 38 38 15.
- Check the tank anode (for glass-lined tanks only) every 3 years
- PTRV check every 6 months: Test the manual relief by lifting the lever. Water should come out of the relief valve. It is recommended that the manual relief be operated every 6 months, so as to flush out any deposits that may accumulate under the seal.

# WARRANTY

Reclaim Energy heat pump hot water system Warranty policy is outlined in this section. This warranty policy is by Reclaim Energy Pty Ltd. Call us on (1300 38 38 15).

## 8.1 TERMS AND CONDITIONS

Note: Product owners are recommended to always keep receipts, invoices, warranties and any installation record forms where applicable, in a safe place to allow faster processing of after sales support requests.

## 8.2 ELIGIBILITY REQUIREMENTS TO MAKE A CLAIM

- The person(s) making the claim must be the product owner or have consent to act on behalf of the owner.
- The person(s) making the claim must contact Reclaim Energy as soon as they notice any defect(s) without excessive delay, and the product must be within its warranty period.
- The product must have its original serial numbers and/or rating labels where applicable.

- The product must be installed in Australia.
- The warranty period begins from the date of installation of the component(s), in the event that proof of installation cannot be provided, the period begins from date of purchase, and in the event that this is also not available, the warranty will begin from date of manufacture of the product plus 3 months.

## 8.3 SUMMARY OF WARRANTY PERIODS

The summary of warranty periods for all major components are shown in Table 12. For all components below, the labour is covered for 2 years ONLY. For more details on the extent of labour work, please refer to section 4.5.

COMPONENT	DESCRIPTION	WARRANTY PERIOD (PARTS ONLY)
Tank	Reclaim Energy Glass-Lined tank	10 years
	Reclaim Energy Stainless steel	15 years
Heat pump	PCB (main)	6 years
	PCB display	
	Motor	
	Sensors * 6 (Compressor charge/discharge, water inlet/outlet, ambient and frost thermistors)	
	Reactor	
	Expansion valve coil	
	Water Pump	
Refrigeration components (compressor, evaporator, water heat exchanger)- Unit replacement		
Controller	Reclaim Energy Controller and sensor lead	2 year
Valves	850 kPa PTRV	1 year

Table 12: Component warranty table.

\* Reclaim Energy covers the labour for 2 years and heat pump compressor parts for 6 years. Service costs are capped as per service schedule of rates being 2 hours labour maximum including travel up to 25km. Travel charge outside of this 25km range to be paid by customer.

## WARRANTY CONT.

## 8.4 GENERAL WARRANTY CONDITIONS

- 1 Failing to install or maintain the system per instructions of the installation manual may void the warranty.
- 2 This Warranty is for Reclaim Energy domestic use of the hot water heating only. Any application with hot water consumption above 700 L/day is considered NON residential. Domestic is defined per below:
  - a. Units installed in any domestic dwelling.
  - b. Hot water consumption below 700 Litres per day.
- 3 To the extent that a claim falls under the 'Parts Only' Warranty Period, the Warranty covers the repair and/or replacement of such failed component in domestic use free of charge. However, the transport, installation and labor costs of repairing the component or delivering the replacement component and removing and replacing the existing component will be the responsibility of the Customer of the existing component.
- 4 To the extent that a claim falls under the 'Parts and Labor' Warranty Period, the Warranty covers the repair and/or replacement of such failed component in domestic use and any associated labor costs free of charge. Please note the cost of freight is for customer to pay.
- 5 The decision to repair or replace the component that is the subject of the Warranty will be entirely at the discretion of Reclaim Energy.
- 6 Where a Reclaim Energy component, as per Table 12, in domestic use, is repaired or replaced by Reclaim Energy, the balance of any original Warranty Period will remain effective. The repaired or replaced part does not carry any additional warranty period.
- 7 Reclaim Energy reserves the right to alter the design, components or construction to its Reclaim Energy Australia Domestic hot water system or custom design. Such alterations shall not constitute a defect in design or construction under this Warranty.
- 8 Any claim under this Warranty must include full details of the defect and/or damage to the Reclaim Energy Australia Domestic hot water system or component(s) in domestic use. All claims must be made within one (1) month of the detection of the defect.
- 9 Dated proof of purchase is required prior to commencement of any work under this Warranty.
- 10 Reclaim Energy does not warrant any installation work conducted by the installer of the RECLAIM ENERGY Domestic hot water system or component(s) in domestic use.
- 11 This Warranty only applies to the Reclaim Energy domestic hot water system and its components, or component(s) in domestic use and does not cover any plumbing or electrical associated parts, including but not limited to any parts supplied by any person installing the Reclaim Energy Domestic hot water system or component(s) in domestic use.
- 12 To the extent permitted by law, Reclaim Energy shall not be liable under this Warranty for any consequential loss or damage or any incidental expenses resulting from any breach of this warranty, including but not limited to, claims for damage to buildings, roofs, ceilings, walls, foundations, gardens, personal belonging or household effects, fixtures and fittings, or any other consequential loss, damage or inconvenience, either directly or indirectly due to leakage from the Reclaim Energy domestic hot water system or component(s) in domestic use or any other matter related to the system or its operation.
- 13 The benefits conferred by this Warranty are in addition to all other rights and remedies in respect of the Reclaim Energy Domestic hot water system or component(s) in domestic use, which the purchaser has under the Competition and Consumer Act 2010 and consumer protection legislation of the States and Territories. Nothing in this Warranty has the effect of excluding, restricting or modifying those rights.
- 14 Goods presented for repair may be replaced by refurbished goods of same type rather than being repaired. Refurbished parts may be used to repair/replace the goods.
- 15 This Warranty is effective for all Reclaim Energy Domestic hot water system or component(s) in domestic use installed after 1st January 2019.
- 16 If the Customer has not paid in full for the Reclaim Energy Domestic hot water system or component(s) in domestic use then this Warranty does not apply (Proof of purchase is a MUST).
- 17 The Reclaim Energy domestic hot water system and its components or component(s) in domestic use are covered by a warranty against defective factory parts or workmanship from the date the Reclaim Energy domestic hot water system or component(s) in domestic use is installed for the relevant period for such component as outlined in Table 12 – Warranty Periods. If the date of installation is unknown, the Warranty commences three (3) months after the date of manufacture.
- 18 Reclaim Energy goods come with guarantees that cannot be excluded under the Australian Consumer Law. You are entitled to a replacement or refund for a major failure and compensation for any other reasonably foreseeable loss or damage. You are also entitled to have the goods repaired or replaced if the goods fail to be of acceptable quality and the failure does not amount to a major failure.
- 19 Reclaim Energy heat pump hot water system are covered by Reclaim Energy for any cost of labor and parts in the event of a Component failure due to any defects that may arise either from workmanship and or faulty material. The Warranty commences on the date of installation.

20 Reclaim Energy does not accept liability for consequential damage or any incidental expenses resulting from any breach of the Warranty.

21 The Reclaim Energy warranty does not cover the following:

- a Subject to any statutory provisions to the contrary, claims for damages to walls, foundations etc. or any other consequential loss caused either directly or indirectly by leakage from the heat pump hot water system or any other faults.
- b Warranty does not cover any faults that may arise from connecting to a water source that is unfiltered such as dams, bores, rivers etc.

22 The warranty will be rendered void in the following circumstances

- a Failure due to misuse, natural disasters, Acts of God, accidental damage, installation by an installer who is not unauthorized to install a Reclaim Energy heat pump hot water system or incorrect installation and attempts to repair Reclaim Energy by an unqualified person.
- b Repairs and service carried out by a person who is not a Qualified Service Person or Authorized Service Agent.
- c Faults caused by incorrect installation, water problems and or electricity supply.

23 Where the Reclaim Energy heat pump hot water system is installed in a position that does not allow safe, ready access, the cost of accessing the site safely, including the cost of additional materials handling and/or safety equipment, shall be the owner's responsibility.

24 This Warranty does not apply to any defects or damage NOT due to faulty factory parts or workmanship including, but not limited to, defects or damage caused by or resulting from:

- 1 Accidental damage, storm damage, vandalism, failure due to misuse or abuse, or neglect of any kind.
- 2 Incorrect or improper installation of the Reclaim Energy heat pump hot water system, including but not limited to, installation otherwise than in accordance with the instructions contained in the owner's manual supplied by Reclaim Energy or incorrect system selection.
- 3 Alteration or repair of the Reclaim Energy Hot Water Heating System other than by a licensed plumber or by an approved Reclaim Energy agent.
- 4 Attachment of any parts or accessories other than those manufactured or approved by Reclaim Energy.
- 5 Freezing in regions with minimum temperatures below -10 C.

6 The power supply to the Reclaim Energy Hot Water Heating System being cut;

- a. power surges;
- b. animals, birds and/or rodents;
- 7 Excessive water pressure, negative pressure (partial vacuum), excessive temperature, corrosive atmosphere.
- 8 Faulty plumbing and/or electrical wiring.
- 9 Sludge/sediment as a result of connection to a water supply from filtered or treated sources ie. spring, dam, bore, river or town supply from a bore.
- 10 Contamination and corrosion from particles in the water supply.
- 11. Serial tags/stickers on any of the components being removed or defaced.
- 12. The Reclaim Energy Hot Water Heating System being relocated from its original point of installation.

## 8.5 HEAT PUMP WARRANTY CONDITIONS

1. All Reclaim Energy heat pump hot water system must be installed by a licensed installer.
2. Only a licensed professional must Install, Commission or Service Reclaim Energy heat pump hot water system.
3. All Reclaim Energy heat pump hot water system must be installed in accordance with Manufacturer's Installation Instructions and in Accordance with local regulations, municipal building codes and current AS/NZS 3000, AS/NZS 3500, AS 3498 and AS/NZS 5601.
4. If the Reclaim Energy heat pump hot water system has not been installed in accordance with Manufacturer's Installation Instructions or installed as to be easily accessible for servicing, a service charge may apply.
  1. The integration with tank and controller should follow the instructions in the installation manual.
  2. The operational conditions should not exceed from those specified in the installation manual (i.e. -10 to 43°C).
  3. The storage tank MUST have a 850 kPa PTRV installed, while the main cold pressure to the hot water system is limited by a 500 kPa PLV.
  4. Electricity supply to the heat pump unit must be accordance with the relevant Australian standards as well as guidelines in the installation manual (i.e. 240 V supply and 20 A circuit breaker).

## WARRANTY CONT.

5. An external controller MUST be connected to the heat pump unit that controls the operation of heat pump. Note that an external controller is integrating storage tank and the heat pump unit.
5. Where a component may have failed under warranty and is replaced, the component replaced will only be covered by the warranty for the balance of the appliance warranty period.
6. Water quality must be within limits specified in Table 13.

## 8.6 TANK WARRANTY CONDITIONS

### 8.6.1 RECLAIM ENERGY STORAGE TANKS

- i. Note that the water quality parameters must not be exceeded as Table 13.
- ii. Any system alteration such as replacing a PTRV not rated to the specification of the manufacture or over exceeding temperature/pressure due to non-compliance installation with regards to Australian standards and/or installation manual will void the warranty.
- iii. Alterations or repair of the Unit other than by an accredited and licensed service agent or technician are not covered. Attachment of accessories or use of non-genuine replacement parts other than those manufactured or approved by the tank manufacturer are not covered by this Warranty.
- iv. With regard to labor, apply within State Capital City metropolitan areas, as determined by Reclaim Energy. Outside these areas, the unit or parts are to be returned, unless otherwise arranged, to Reclaim Energy or a service agent nominated by Reclaim Energy. All freight and insurance charges (both ways) are the responsibility of the owner. When making a warranty claim, it is the responsibility of the owner to provide proof of original purchase and the date of installation. The unit must be installed by appropriately qualified tradesperson in accordance with relevant industry standards and local statutory authority regulations. Responsibility for repairs to the unit will not be accepted unless authorization to carry out repairs has been previously given by Reclaim Energy. Where a warranty claim has been made and it is found that the fault is not within the unit, all costs will be charged to the owner. The warranty does not extend to any consequential loss or damage, which may be a result of the operation or non-operation of this unit, subject to any statutory warranty to the contrary.
- v. This Warranty applies only to the Unit and does not cover any ancillary plumbing or electrical parts supplied by the installer such as pressure limiting valve, tempering valve, line strainer, stop cocks, non-return valve, electrical switches, pumps or fuses, or faulty installation.

<b>Total Dissolved Solids</b>	< 600 mg/L or ppm
<b>Total Hardness (CaCO<sub>3</sub>)</b>	< 200 mg/L or ppm
<b>Electrical Conductivity</b>	850 µS/cm
<b>Chloride</b>	< 300 mg/L or ppm
<b>pH Level</b>	Min 6.5 to Max. 8.5
<b>Magnesium</b>	< 10 mg/L or ppm
<b>Sodium</b>	< 150 mg/L or ppm
<b>Iron</b>	< 1mg/L or ppm
<b>Alkalinity (as CaCO<sub>3</sub>)</b>	< 200 mg/L or ppm
<b>Dissolved (free) CO<sub>2</sub></b>	< 25 mg/L or ppm

Table 13 Water quality requirement for Reclaim Energy Hot Water Heat Pump Installation.

- vi. The Unit must be installed by a licensed tradesperson in accordance with the instructions set out in the manual supplied with the Unit and/or any relevant statutory requirements. If the Unit is located in a position that does not comply with the installation instructions or relevant statutory requirements, then this Warranty does not cover major dismantling or removal of cupboards, doors, walls or special equipment and/ or excessive labour, at the determination of the tank manufacturer, to make the Unit accessible for repair or replacement.
- vii. As required by legislation, any claims for damage to furniture, carpets, walls, foundations or any other consequential loss either directly or indirectly due to defects of any kind in a Unit will only be met by the tank manufacturer where the damage could be considered reasonably foreseeable and the installed unit complies with the manufacturers installation instructions and all relevant statutory requirements.
- viii. In addition to this Warranty, certain legislation (including the ACL) may give you rights which cannot be excluded, restricted or modified. This Warranty must be read subject to such legislation and nothing in this Warranty has the effect of excluding, restricting or modifying those rights.
- ix. If the tank manufacturer fails to meet a guarantee under the ACL, your remedy for such failure may be limited to any one or more of the following:
  - a. Replacement of the Unit.
  - b. Repair of the Unit.
  - c. Payment of reasonable costs of having the Unit repaired.

### 8.6.2 RECLAIM ENERGY GLASS-LINED TANK

- i. Reclaim Energy glass-lined storage vessels against faulty workmanship and materials. This warranty shall not apply to such Unit or part thereof, which has been the subject of fixed temperature settings in excess of 80oC, or if any repairs have been made by any person not approved by Reclaim Energy.
- ii. For this tank, Reclaim Energy Will;
- iii. For the period up to and including the 10th year after the date of installation: repair or replace defective components or, at the discretion of Reclaim Energy provide a replacement unit or parts. Note that the cost of labour to repair the unit will be the responsibility of the customer after the first year.

### 8.6.3 RECLAIM ENERGY STAINLESS STEEL TANKS

The warranty does not apply to cosmetic defects, accidental damage, misuse or abnormal use of the heat pump hot water system or discoloration of the surface or tarnishing of fittings from adverse conditions, all of which require normal service to maintain them. The full replacement is within first 6 years, and from year 7 through to year 15 from date of purchase, Reclaim Energy shall replace or repair on a pro-rata basis set out in the scaling scale below:

- 1. Year 7: Reclaim Energy 90%- Customer 10%**
- 2. Year 8: Reclaim Energy 80%- Customer 20%**
- 3. Year 9: Reclaim Energy 70%- Customer 30%**
- 4. Year 10: Reclaim Energy 60%- Customer 40%**
- 5. Year 11: Reclaim Energy 50%- Customer 50%**
- 6. Year 12: Reclaim Energy 40%- Customer 60%**
- 7. Year 13: Reclaim Energy 30%- Customer 70%**
- 8. Year 14: Reclaim Energy 20%- Customer 80%**
- 9. Year 15: Reclaim Energy 10%- Customer 90%**

Note that the % represents the proportion the customer will pay based on the current Reclaim Energy price list for material and labor (where applicable).

## 8.7 CONTROLLER WARRANTY CONDITIONS

The following information may be required to determine if the Product issue is eligible for coverage under the terms of this Limited Warranty.

- 1 Information related to the manner in which the Product was installed.
- 2 The history of operation.
- 3 Any repairs that may have been made.
- 4 Evidence that the Product was installed by a qualified, licensed contractor.
- 5 Evidence that the Product was installed in accordance with the applicable Products Installation Manuals and any special written design or installation guidelines by Reclaim Energy.
- 6 Evidence that the Product was installed in accordance with all applicable local building, plumbing and electrical codes.

This warranty shall be void and shall have no effect if:

- (a) The design or structure of the Product is attempted to be modified or altered in any way, including by not limited to attaching non- Reclaim Energy approved appliances or equipment;
- (b) The Product is not installed or repaired in accordance with applicable local codes;
- (c) The Product is not installed by qualified, suitably licensed persons;
- (d) The installation was not completed in line with the guidelines of the then current Reclaim Energy installation manual;
- (e) Product serial tag or other identification is defaced or removed;
- (f) Any operation exceeds the documented design limits of the system components or materials. (g) Temperature sensors fail due to water ingress, electrical shorting, or electrical interference; (h) Product is installed in an environment that exceeds the specified operating range;
- (g) Failure is due to lightning damage, electrical power interruption or dirty power supply;

## 8.8 WARRANTY REGISTRATION LODGE A CLAIM

For all warranty issues please call Reclaim Energy on:

Tel: **1300 38 38 15** or  
Email: **warranty@reclaimenergy.com.au**

Provide full product owner's contact details: name of owner, address of installation site, contact number(s), proof of original installation date or if not available, the date of manufacturing and serial number from the rating label, where applicable for heat pump hot water system and tanks.

Please supply a photo of serial number as well as the faulty parts.

### PRODUCT REGISTRATION

In order to register your system for warranty purposes, please complete the details of your purchase.

#### ONLINE

Fill in the form on our website:  
**reclaimenergy.com.au/warranties**

#### POST

Fill in the form on page 9 and send to:

**Reclaim Energy Pty Ltd**  
**PO Box 627**  
**Byron Bay**  
**NSW 4181**

#### EMAIL

**warranty@reclaimenergy.com.au**

## YOUR WARRANTY DETAILS

Please fill in and keep for your records

Your name: \_\_\_\_\_

Your mailing address: \_\_\_\_\_

State: \_\_\_\_\_ Postcode: \_\_\_\_\_

Product Details: \_\_\_\_\_

Heat Pump Serial Number: \_\_\_\_\_

Hot Water Tank Serial Number: \_\_\_\_\_

Date of Purchase/Installation: \_\_\_\_\_ / \_\_\_\_\_ / 20 \_\_\_\_\_

Suppliers Name: \_\_\_\_\_



THIS PAGE WAS INTENTIONALLY LEFT BLANK

THIS PAGE WAS INTENTIONALLY LEFT BLANK



1300 383 815

HELLO@RECLAIMENERGY.COM.AU

**RECLAIMENERGY.COM.AU**

facebook.com/CO2HeatPump 

instagram.com/reclaimenergy 



**RECLAIM**  
ENERGY